

# VR BUBBLE COASTER

## PRODUCT OVERVIEW

The SpongeBob VR Bubble Coaster, manufactured by Rilix LLC and marketed by Andamiro USA Corp., is an unattended, away-from-home virtual reality attraction featuring content appropriate for all audiences. It is designed for two distinct purposes:

**1 - as a player-operated amusement device.**

**2 - a commercial appliance for owners and operators of family entertainment centers and arcades.**

As an unattended commercial appliance, it can also be deployed at shopping malls, retail centers, skating rinks, arenas and bowling alleys, among other highly trafficked public locations, by amusement vending machine operators.

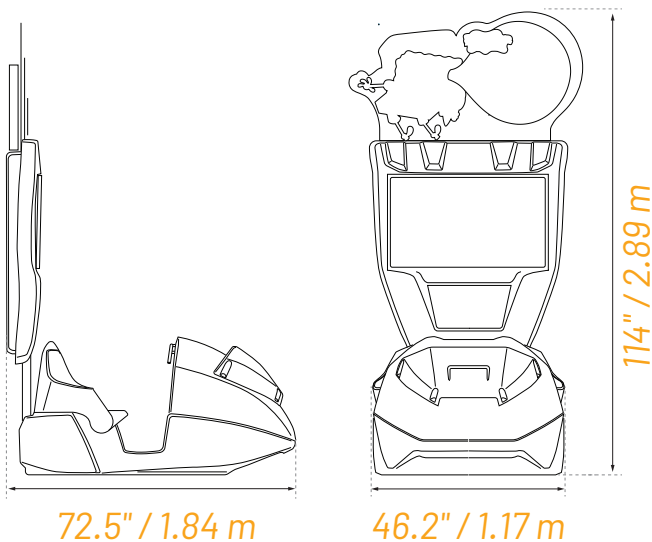

## SIMULATOR DIMENSIONS

Depth: 72.5" / 1.84 m  
Width: 46.2" / 1.17 m  
Height: 114" / 2.89 m  
Weight: 352 lbs. / 159 kg



## COMPONENT BOARD AND ELECTRICAL CONSUMPTION

The Bubble Coaster VR simulator requires a 110 or 220 volts power outlet with a standard three-prong plug. In addition, the electrical network must be grounded, thus ensuring the correct functioning of the simulator.

Below is the detailed table of the simulator components and their consumption.

Item	Equipment	Operation Voltage (volts)	Maximum power (watts)
1	Power Supply	220/110	600
2	NUC	220/110	65
3	Monitor	220/110	27
4	USB Hub	220/110	24
5	Sound System	12	280
6	Wind System	12	120
7	Bill Acceptor	12	10
8	Card Reader	12	10

Note 1: A 600-watt ATX power supply powers all 12/24-volt equipment.

### Wind system:

4x - 12 volt cooling fans  
1x - PWM controller circuit.

### Sound System:

2x - six-inch, 100-watt speakers  
1x - 50-watt bass shaker  
1x - 280-watt sound amplifier.

The virtual reality goggles are powered by an externally powered USB 3.0 hub, which ensures the battery charge of the glasses even with overuse.

## TABLE CONSUMPTION AND POWER.

Operating Voltage (volts)	Equipment	Maximum power (watts)	Maximum current (ampere)
220	Bubble Coaster	796	3.6
110	Bubble Coaster	796	7.23

# MAXIMUM MONTHLY ELECTRICITY CONSUMPTION.

Average monthly consumption (30 days)

286,56 kWh

Note 2: The calculation is based in a 12 hours/day operating routine.

## ELECTRICAL DIAGRAM

Functional electrical diagram of the VR Bubble Coaster Machine simulator.

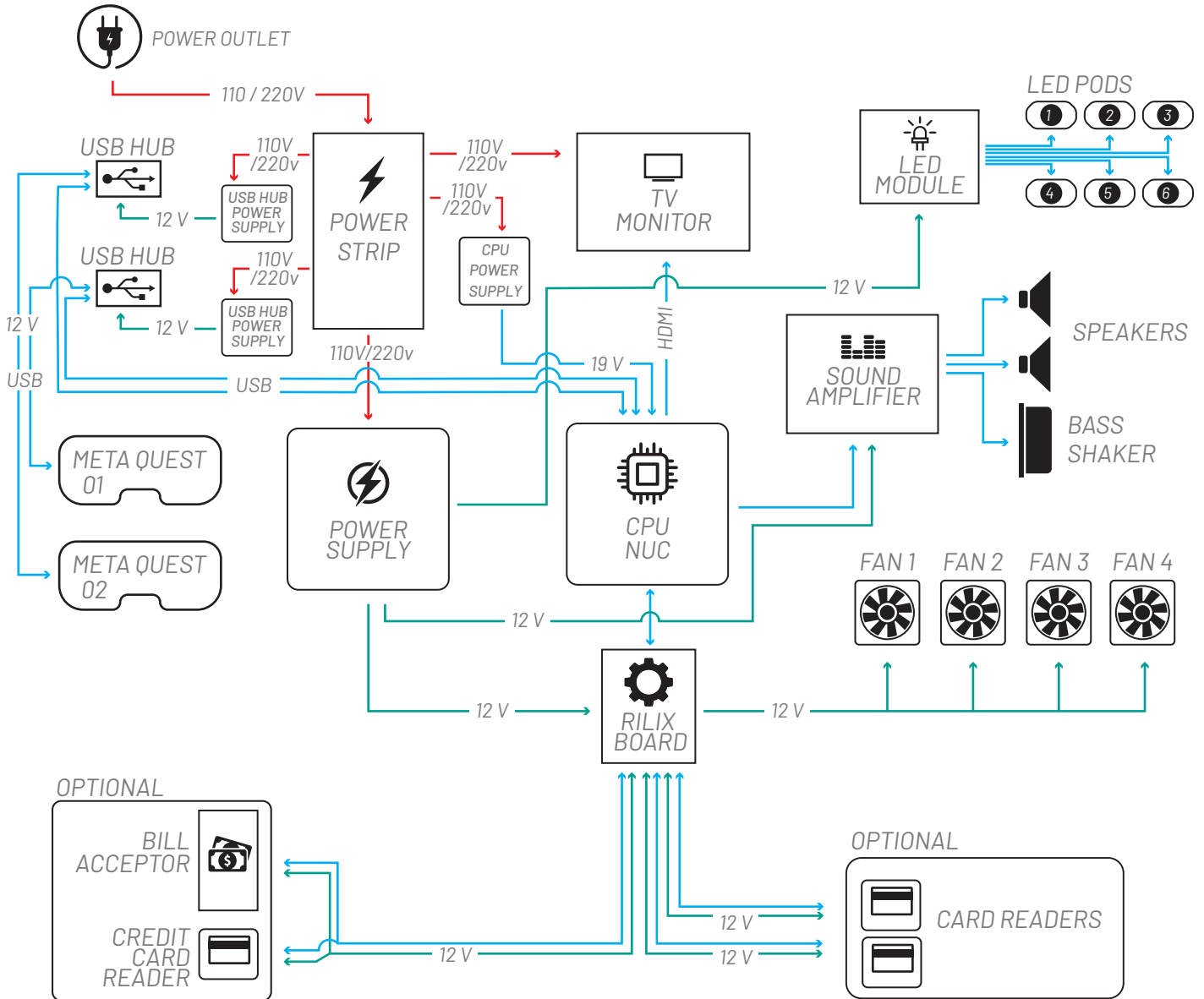

Rilix LLC | 700 S. John Rodes Blvd Ste E5  
Melbourne, FL 32904 - U.S.A

