





SERVICE MANUAL



[IMPORTANT]

- ▶ Please read the manual carefully and keep it in mind before using this machine
- ▶ Put this manual within touch of your reference in anytime.

ISSUE DATE: May. 2, 2024

PRODUCT INFO	PART INFO	SUPPORT INFO	NEW PRODUCT INFO
			

※ QR(SUPPROT) - Leaflets, manuals, solution(error code, trouble shooting document, watch&solve)

PRECAUTIONS FOR USE

The following safety precautions are given throughout this manual. They must be strictly followed to protect those who install, use or maintain this product as well as to protect players, visitors and property.

For safety reasons.

- The following suggestions should be adhered to:



WARNING

Disregarding could result in serious injury.



CAUTION

Disregarding could result in injury or product damage.

- The following graphic suggestions describe the types of precautions to be followed.



Indicates a care should be taken.



Forbidden.



Indicates a matter which must be performed.

- **Precautions to be followed:**

Certain procedures require a qualified in-shop maintenance person or industry specialist.

For such instructions, a qualified person must take care of the jobs.

- Otherwise an electric shock, machine trouble or a serious accident may result.
- Replacing the machine parts, inspecting and maintaining the machines and troubleshooting must be assigned only to a qualified in-shop maintenance person or industry specialist. This booklet gives instructions that hazardous jobs in particular must be handled by an industry specialist. Qualified in-shop maintenance person and industry specialist are defined as follows.

Qualified in-shop maintenance person

- A service staff shall have experience in operations of game machines. The staff shall be responsible for assembly, installation, inspection and maintenance of the machine.

Industry specialist

- An industry specialist must be engaged in designing, manufacturing, inspecting and servicing amusement machines. He or she must have an education in electrical, electronic and mechanical engineering and routinely maintain and repair amusement machines.

PRECAUTIONS FOR USE

WARNING

Be sure to consult an industry specialist when setting up, moving or transporting this product.

- This product should not be set up, moved or transported by any one other than an industry specialist.
- When installing this product, set the 4 leg levelers evenly on the floor and make sure that the product is installed stably in a horizontal position. Unstable installation may result in injury or accident.
- When installing this product, do not apply undue force on movable parts. Otherwise, injury and accident may result, or the product may be damaged.

The machine for indoor usage only does not install outside.



Do not set the game machine up near emergency exits.



Protect the game machine from:

- Rain or moisture.
- Direct sunlight.
- Direct heat from air-conditioning and heating equipment, etc..
- Hazardous flammable substances.
- Otherwise an accident or malfunction may result.



Do not place containers holding chemicals or water on or near the game machine.



Do not place objects near the ventilating holes.



Do not bend the power cord by force or place heavy objects on it.



Never plug or unplug the power cord with wet hands.



Never unplug the game machine by pulling the power cord.



CAUTION

Be sure to use indoor wiring within the specified voltage requirements. For extension cord, use the specified rating or more.

Be sure to use the attached power cord.

Never plug more than one cord at a time into the electrical receptacle.



Do not lay the power cord where people walk through.



Be sure to ground this product.



Do not exert excessive force when moving the machine.



For proper ventilation, keep the game machine 100mm(4") away from the walls.

Do not alter the system related dipswitch settings.

PRECAUTIONS FOR USE

WARNING

If there is any abnormality such as smoke, bad smell or abnormal noise being emitted from the machine, immediately turn OFF the main power switch and unplug the power cord from the receptacle to stop operating it. 

- Using the machine in abnormal conditions could result in fire or accidents.

In case of abnormality

1. Turn OFF the main power switch.
2. Unplug the power cord from the receptacle.
3. Contact your nearest dealer.

Do not leave the power cord plugged in improperly or covered with dust. 

- Doing so could result the power cord periodically.

CAUTION

Do not use this product anywhere other than industrial areas. 

- Using in a residential area or an area next to a residential area could affect signal reception of radios, television sets, telephones and etc..
- Do not give shock the surface of glass products.

- Please do not play this game if
 - When you do drinking;
 - When your physical condition is not normal;
 - When you are in pregnancy;
 - When you have on a pulse controller;
 - When you have recently experienced a cramp or fainting away while watching TV.
- Avoid excessive force/shock while playing/moving the game.
- While do games, pay attention to surrounding.

Do not plug or unplug the power cord with wet hands. 

In handling the power cord, follow the instructions below. 

- | | |
|---|--|
| • Do not damage the power cord. | • Do not modify the power cord. |
| • Do not bend the power cord excessively. | • Do not twist the power cord. |
| • Do not heat the power cord. | • Do not pull the power cord. |
| • Do not bind the power cord. | • Do not stand on the power cord. |
| • Do not sandwich the power cord. | • Do not drive a nail into the power cord. |

If the power cord or power plug becomes damaged, stop using the machine immediately and ask your nearest dealer to replace the parts.

*** Electromagnetic wave may cause unexpected noise from speaker.**

PRECAUTIONS FOR USE

⚠ WARNING

Be sure to turn OFF the main power switch and unplug the power cord from the receptacle before inspecting or cleaning the machine.



When replacing parts, be sure to use parts of the correct specifications. Never use parts other than the specified ones.



Opening inside the machine shall be done by machine specialist only as high electric current is being sent inside. For game machine with monitor, a care should be taken while opening its back door. If not, a damage to the inside parts or the monitor may occur.



If the sub power switch of the service panel is turned OFF without turning OFF the main power switch of the power supply unit, some parts in the units remain live. When opening the back door, be sure to turn OFF the main power switch and unplug the power cord from the receptacle.



Strictly refrain from disassembly and repair of parts which are not indicated in this manual, as well as settings and remodeling.



To clean the game machine, wipe it with a soft cloth dampened in a neutral detergent.

- Using thinner or other organic solvent or alcohol may decompose the material.
- Electrical shock or equipment failure could be caused by water entering the inside of the machine.

⚠ CAUTION

Components in the game are sensitive to vibrations and impact. Care should be used when moving and transporting the game machine.



Be sure not to let the machine tip over.

Before moving the machine, be sure to turn OFF the main power switch, unplug the power cord from the receptacle and remove the power cord from the machine.



Before moving take the machine, off the levelers and move it on the casters.

Avoid excessive force while moving the machine.

.....

PRECAUTIONS IN HANDLING

- When setting up, inspecting, maintaining, moving or transporting this product, follow the procedures and instructions set forth in this manual and perform such work safely.
- Do not set up, handle, inspect, maintain, move or transport this product under conditions equivalent to the condition of "WARNING" or "CAUTION" specified in this manual.
- If a new owner is to have this product as a result of transfer, and etc., be sure to give this manual to the new owner.

PRÉCAUTION D'EMPLOI

Les consignes de sécurité suivantes sont données dans ce manuel. Elles doivent être strictement suivies pour protéger ceux qui les installent. Utiliser ou entretenir ce produit pour la sécurité des utilisateurs, des visiteurs et des biens.

Pour des raisons de sécurité.

- **Les suggestions suivantes doivent être respectées:**

ATTENTION

Le non-respect peut entraîner des blessures graves.

PRUDENCE

Le non-respect peut entraîner des blessures ou des dommages au produit.

- **Les suggestions graphiques suivantes décrivent les types de précautions à prendre.**



Indique qu'attention est requise.



Interdit.



Indique que quelque chose doit être effectuée.

- **Les précautions à prendre :**

Certaines procédures exigent une personne de maintenance qualifiée en atelier ou un spécialiste de l'industrie. Pour ces instructions, une personne qualifiée doit prendre soin des travaux.

- Sinon, un choc électrique, un dysfonctionnement de la machine, ou un accident grave peut en résulter.
- Remplacement des pièces de machines, l'inspection et la maintenance des machines, et le dépannage doit être attribué qu'à une personne de maintenance qualifiée en atelier ou spécialiste de l'industrie. Cette brochure donne des instructions que les emplois dangereux, en particulier, doivent être traités par un spécialiste de l'industrie. La personne de maintenance qualifiée en atelier et le spécialiste de l'industrie sont définis comme suit.

La personne de maintenance qualifiée en atelier

- Un personnel de service doit avoir de l'expérience dans les opérations de machines de jeux. Le personnel est responsable pour l'assemblage, l'installation, l'inspection et l'entretien de la machine.

Le spécialiste de l'industrie

- Un spécialiste de l'industrie doit être engagé dans la conception, la fabrication, l'inspection et l'entretien des appareils d'amusement.
Il ou elle doit avoir une formation en génie électrique, électronique et mécanique, et de maintenir régulièrement et de réparer les appareils d'amusement.

PRÉCAUTION D'EMPLOI

ATTENTION

Si il y a une anomalie comme fumée, mauvaise odeur ou bruit anormal émis par la machine,  couper immédiatement l'interrupteur principal et débranchez le câble d'alimentation de la prise pour arrêter son fonctionnement.

- L'utilisation de l'appareil dans des conditions anormales peut provoquer un incendie ou un accident.

En cas d'anomalie

1. Mettez l'interrupteur principal sur ARRÊT.
2. Débranchez le câble d'alimentation de la prise.
3. Contactez votre revendeur le plus proche.

Ne pas brancher le câble d'alimentation incorrectement ou le laisser être recouvert de poussière. 

Cela pourrait nuire le câble d'alimentation.

PRUDENCE

Ne pas utiliser ce produit ailleurs que dans les zones industrielles. 

- L'utiliser dans une zone résidentielle ou d'une zone à côté d'un quartier résidentiel pourrait nuire à la réception des radios, téléviseurs, téléphones, etc.
- Ne donnez pas de choc à la surface d'un produit en verre.

- S'il vous plaît ne pas jouer à ce jeu.
 - Quand vous buvez;
 - Lorsque votre condition physique n'est pas normale;
 - Lorsque vous êtes dans une période de grossesse;
 - Lorsque vous avez un contrôleur d'impulsion;
 - Lorsque vous avez récemment subi une crampe ou évanouissement en regardant la télévision.
- Évitez une force excessive / un choc pendant la lecture / de déplacer le jeu.
- Quand vous jouez les jeux, faites attention aux alentours.

Ne pas brancher ou débrancher le câble d'alimentation avec les mains mouillées. 

Dans la manipulation du câble d'alimentation, suivez les instructions ci-dessous. 

- | | |
|--|---|
| • Ne pas endommager le câble d'alimentation. | • Ne pas modifier le câble d'alimentation. |
| • Ne pas plier le câble d'alimentation de manière excessive. | • Ne tordez pas le câble d'alimentation. |
| • Ne pas chauffer le câble d'alimentation. | • Ne tirez pas sur le câble d'alimentation. |
| • Ne pas lier le câble d'alimentation. | • Ne montez pas sur le câble d'alimentation. |
| • Ne pas prendre en sandwich le câble d'alimentation. | • Ne pas mettre un clou dans le câble d'alimentation. |

Si la fiche du câble d'alimentation ou est endommagé, cessez immédiatement d'utiliser la machine et demandez à votre revendeur le plus proche de remplacer les pièces.

PRÉCAUTION D'EMPLOI

⚠ ATTENTION

Assurez-vous de consulter un spécialiste de l'industrie lors de la mise en place, du déplacement ou le transport de ce produit.

- Ce produit ne doit pas être mis en place, déplacé ou transporté par une quelconque autre qu'un spécialiste de l'industrie.
- Lors de l'installation de ce produit, installez 4 niveleurs de pieds uniformément sur le sol et assurez-vous que le produit est installé de façon stable dans une position horizontale. Une installation instable peut entraîner des blessures ou un accident.
- Lors de l'installation de ce produit, ne pas appliquer une force excessive sur les pièces mobiles. Sinon, des blessures et des accidents peuvent y résulter, ou le produit peut être endommagé.

La machine pour une utilisation en intérieur uniquement, ne pas installer à l'extérieur.



N'installez pas la machine de jeu près des issues de secours.



Protéger la machine de jeu de:



- L'humidité ou la pluie.
- La lumière directe du soleil.
- La chaleur directe de la climatisation et du chauffage, etc...
- Des substances inflammables dangereuses.
- Sinon, un accident ou un dysfonctionnement.

Ne pas placer les récipients contenant des produits chimiques ou de l'eau sur ou près de la machine de jeu.



Ne placez pas d'objets à proximité des orifices de ventilation.



Ne pas plier le cordon d'alimentation par la force ou de placer des objets lourds au-dessus.



Ne jamais brancher ou débrancher le cordon d'alimentation avec les mains mouillées.



Ne jamais débrancher la machine de jeu en tirant le câble d'alimentation.



⚠ PRUDENCE

Veillez à utiliser le câblage intérieur selon les exigences de tension spécifiées. Pour une rallonge, utilisez la notation spécifiée ou plus.

Veillez à utiliser le cordon d'alimentation fourni.

Ne jamais brancher plus d'un cordon à la fois dans la prise électrique.



Ne pas poser le cordon d'alimentation où les gens marchent à travers.



Soyez sûr de mettre à la terre ce produit.



Ne pas exercer une force excessive lors du déplacement de la machine.



Pour une ventilation correcte, garder la machine de jeu 100mm (4 ") loin des murs.

Ne pas modifier les réglages des commutateurs DIP liées au système.

PRÉCAUTION D'EMPLOI

ATTENTION

Veillez à éteindre l'interrupteur d'alimentation principale et débranchez le cordon d'alimentation de la prise avant d'inspecter ou de nettoyer la machine. 

Lors du remplacement des pièces, veillez à utiliser une partie des spécifications correctes. Ne jamais utiliser de pièces autres que celles spécifiées. 

L'ouverture à l'intérieur de la machine doit être effectuée par le spécialiste de la machine seulement, comme le courant électrique élevé est transmis à l'intérieur. Pour la machine de jeu avec le moniteur, un soin doit être pris lors de l'ouverture de sa porte arrière. Si non, une détérioration des pièces à l'intérieur ou à l'écran peut se produire. 

Si l'interrupteur secondaire du panneau de service est éteint sans éteindre le commutateur d'alimentation principale de l'unité d'alimentation, certaines parties dans les unités restent sous tension. Lors de l'ouverture de la porte arrière, veillez à éteindre l'interrupteur d'alimentation principale et débranchez le cordon d'alimentation de la prise. 

Il est strictement conseillé de s'abstenir de démonter et de réparer des pièces qui ne sont pas indiqués dans ce manuel, ainsi que les paramètres et le remodelage. 

Pour nettoyer la machine de jeu, l'essuyer avec un chiffon doux imbibé avec un détergent neutre.

- L'utilisation plus mince d'un autre solvant organique ou de l'alcool peut décomposer le matériel.
- Un choc électrique ou une défaillance de l'équipement pourraient être causés par la pénétration de l'eau à l'intérieur de la machine.

PRUDENCE

Les composants de la machine de jeu sont sensibles aux vibrations et aux chocs. Il faut faire attention lors du déplacement et le transport de la machine de jeu. 

Veillez à ne pas laisser la machine se renverser.

Avant de déplacer la machine, veillez à éteindre l'interrupteur d'alimentation principale, débranchez le cordon d'alimentation de la prise et débranchez le cordon d'alimentation de la machine. 

Avant de déplacer la machine, la mettre hors des niveleurs et le déplacer sur les roulettes.

Éviter une force excessive lors du déplacement de la machine.

.....

PRÉCAUTIONS LORS DU MANIEMENT

- Lors de la mise en place, l'inspection, l'entretien, déplacement ou le transport de ce produit, suivez les procédures et les instructions énoncées dans ce manuel et effectuer ce travail en toute sécurité.
- Ne pas mettre en place, manipuler, inspecter, entretenir, déplacer ou transporter ce produit dans des conditions équivalentes à l'état de "ATTENTION" ou "PRUDENCE" spécifiée dans ce manuel.
- Si un nouveau propriétaire obtient ce produit à la suite d'un transfert, etc., soyez sûr de donner ce manuel au nouveau propriétaire.

CONTENTS

1. SPECIFICATION AND DIMENSION	P03
1-1. DIMENSION	P03
1-2. SPECIFICATION	P03
1-3. STICKER LOCATION	P04
2. INSTALL INFOMATION	P05
2-1. INSTALLATION SPACE	P05
2-2. MAINTAIN PRODUCT FLATNESS	P05
2-3. IMPORTANCE	P05
3. COMPONENTS	P06
4. INSTALL	P07
4-1. HOW TO INSTALL_CABINET	P07
4-2. HOW TO INSTALL_BILLBOARD	P14
5. SETUP SETTING	P15
5-1. MACHINE SETUP	P15
5-2. PROGRAM SETTINGS	P16
5-3. CLEAR MODE	P20
5-4. BOOKKEEPING	P20
5-5. TEST MODE	P21
5-6. ERROR CODE	P24
6. MAINTENANCE	P26
6-1. PRECAUTIONS FOR TURNING ON THE POWER	P26
6-2. WHEN INSTALLING THE DEVICE	P26
6-3. MAIN BOARD MANAGEMENT	P26
6-4. BASIC PRODUCT MANAGEMENT CLEAN IT REGULARLY	P26
6-5. THIS PRODUCT SHOULD ONLY BE USED FOR INDOOR USE	P26
7. EXPLODED VIEW	P27
7-1. MAIN CABINET PART	P27
7-2. BILLBOARD LIGHT PART	P28
7-3. BILLBOARD PART	P28
7-4. TARGET TOTAL PART-A, B, C PART	P29
7-5. PLAYER TURN LED PART	P29
7-6. FRONT BUTTON PART	P30
7-7. COIN BOX PART	P30
7-8. SPEAKER PART	P31

7-9. BALL BLOCK PART	P31
7-10. MAIN BOARD PART	P32
7-11. POWER SMPS PART	P32
7-12. CONTROL PANEL PART	P33
7-13. FRONT CASE DOOR PART	P33
8. SOLUTION	P34
9. PCB CONNECTION LOCATION	P36
9-1. MAIN PCB ASS'Y	P36
9-2. 1ST FND EXT IO PCB (MAIN PCB Left)	P36
9-3. 2ND FND EXT IO PCB (TURN LED ASS'Y)	P37
9-4. CHECKER SENSOR RX, TX PCB ASS'Y	P37
9-5. PHOTO INT-1 PCB ASS'Y	P37
9-6. BALL SENSOR PCB ASS'Y	P37
10. BLOCK DIAGRAM	P38
11. WARRANTY ITEM	P46
12. TROUBLE SHOOTING	P48
12-1. REGION ERROR (Er01)	P48
12-2. SYSTEM ERROR (Er02, Er03, Er04)	P48
12-3. COIN MACHINE ERROR (Er.11)	P48
12-4. BILL ACCEPTOR ERROR (Er.12)	P48
12-5. BALL BREAK OPEN MOTOR & SENSOR ERROR (Er.21)	P49
12-6. BALL BREAK CLOSE MOTOR & SENSOR ERROR (Er.22)	P49
12-7. CHECK "No. 1" SENSOR ERROR (Er.31)	P50
12-8. CHECK "No. 2" SENSOR ERROR (Er.32)	P50
12-9. CHECH "No. 3" SENSOR ERROR (Er.33)	P51
12-10. CHECK "No. 4" SENSOR ERROR (Er.34)	P51
12-11. CHECK "No. 5" SENSOR ERROR (Er.35)	P52
12-12. CHECK "No. 6" SENSOR ERROR (Er.36)	P52
12-13. CHECK "No. 7" SENSOR ERROR (Er.37)	P53
12-14. CHECK "No. 8" SENSOR ERROR (Er.38)	P53
12-15. CHECK "No. 9" SENSOR ERROR (Er.39)	P54
12-16. TICKET ERROR (HEP)	P54

1. SPECIFICATION AND DIMENSION

1-1. DIMENSION

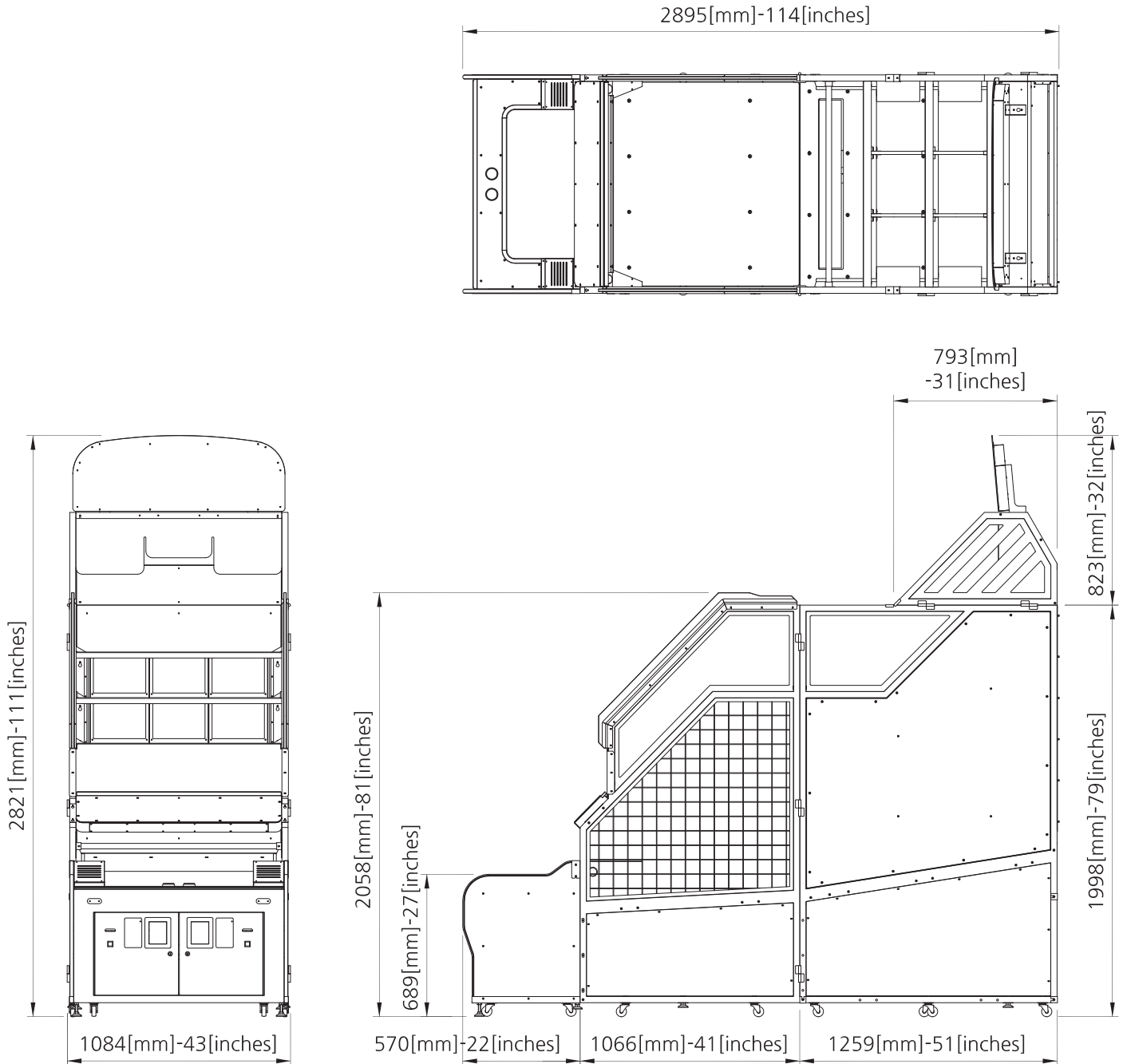

1-2. SPECIFICATION

DIMENSIONS (W x D x H)	1084 x 2895 x 2821 (mm)	
PACKING (W x D x H) DIMENSIONS	FRONT FRAME : 1130 x 780 x 1060 (mm) MAIN FRAME : 1130 x 1220 x 2270 (mm)	
WEIGHT (kg)	FRONT FRAME : 85kg / MAIN FRAME : 348 kg [WEIGHT INCLUDING : FRONT FRAME : 106kg / MAIN FRAME : 392 kg] PACKAGING	
VOLTAGE	AC 120V	AC 230V
FREQUENCY RANGE	60Hz	50/60Hz
CONSUMPTION	270 W	
CERTIFICATION	-	

1-3. STICKER LOCATION

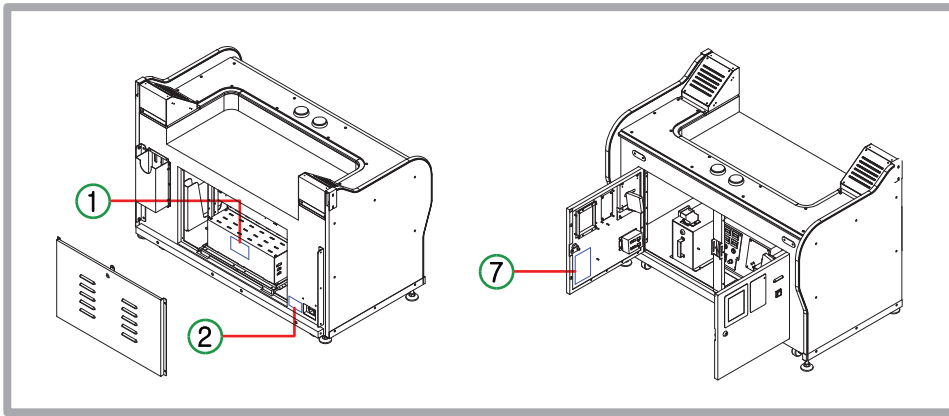

POWER SMPS

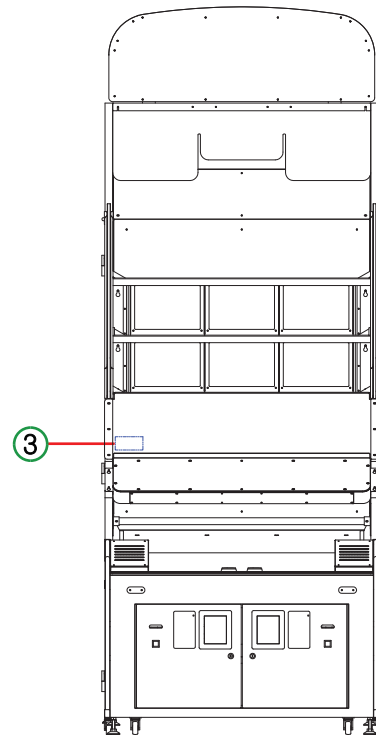
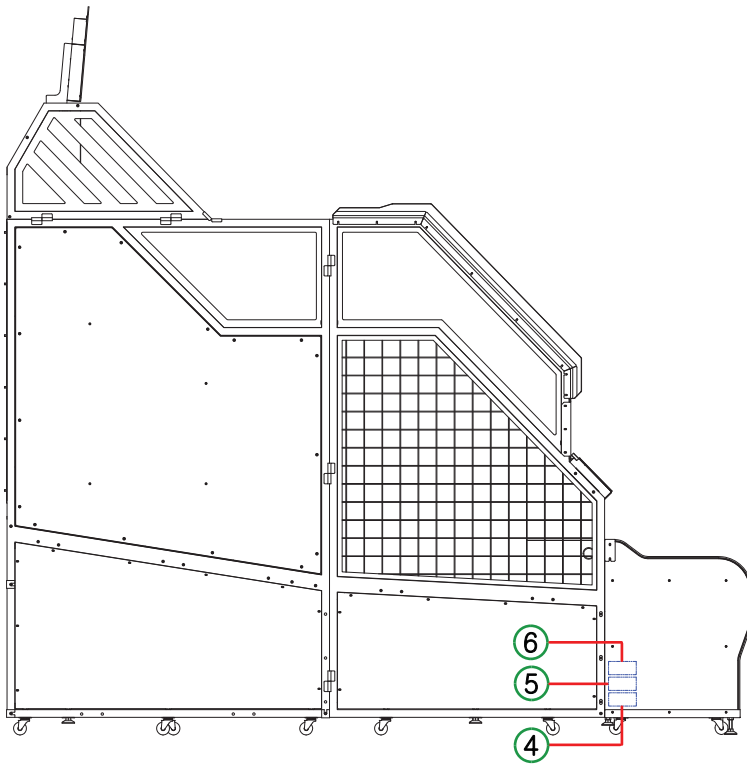

1

⚠ WARNING/ATTENTION	
	Except service personal, please never open the product as there is a risk of electric shock. Il y a un risque d'électrocution, n'ouvrez pas le produit excepté le responsable, s'il vous plaît.

2

⚠ CAUTION/PRUDENCE	
For continuous protection against risk of fire, replace only with the same type T10A-250V fuse	
Pour une protection continue contre les risques d'incendie, remplacer un fusible avec seulement le même type T10A-250V	

3

	Do not push or hit this. It would be damaged. Ne pas la pousser ou frapper. Elle serait endommagée.
--	--

4

MODEL NAME	
PRODUCT S/N	
MAIN BOX S/N	
LOD S/N	
CERTIFICATE	
MADE IN KOREA	
Koyang-si, Kyunggi-do, Korea. Phone: 82-31-908-2100	

5

WARNING	
ROCKING, SWAYING, OR TIPPING MAY CAUSE INJURY OR DEATH! This unit must be fastened securely to the wall, floor or adjacent object in compliance with the installation instructions.	
ATTENTION	
AGITER, SECOUER OU MASCLER PEUT CAUSER DES BLESSURES OU ENTRAINER LA MORT! Cette unité doit être fixée au mur, au plancher ou à un objet à proximité conformément aux instructions d'installation.	

6



7

A simple record of your server's history	
DATE	REMARKS

2. INSTALL INFORMATION

*** PLEASE DO NOT INSTALL PRODUCT IN A PLACE WITH A LOT OF SUNLIGHT. IT CAN BE A PROBLEM FOR THE OPERATION OF THE PRODUCT.**

2-1. INSTALLATION SPACE

- ※ Maintenance zone & Play zone should have at least 2500mm(99 inch) * 4000mm(157inch) each

2-2. MAINTAIN PRODUCT FLATNESS

- ※ After installation is complete
- ※ 2-1 After securing space, adjust the 4 adjuster so that the product is stably leveled





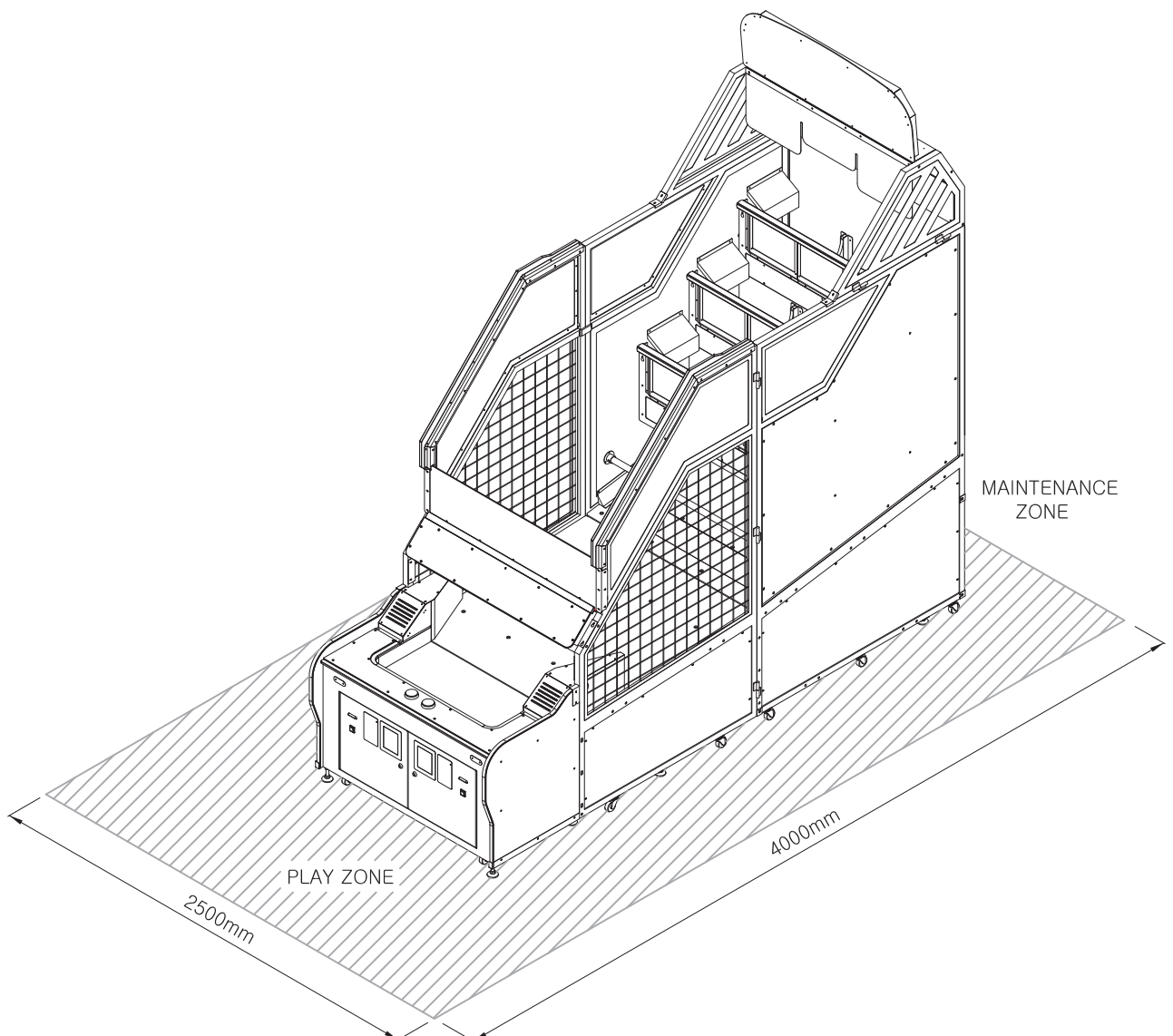





2-3. IMPORTANCE

- ※ **This product should be indoor use and out of direct sunlight**



3. COMPONENTS

NO	PART NAME	Q'TY	SPARE
1	AC POWER CORD	1	
2	KEY 7001	2	
3	SCREW TH [M4x10L]	12	4
4	SCREW TH [M4x16L]	48	4
5	SCREW TH [M6x30L]	8	4
6	SCREW TH [M6x50L]	26	4
7	SCREW TH [M6x20L]	8	4
8	SCREW TH [M8x50L]	2	4
9	RENCH [3mm]	1	
10	BASKET BALL [ORANGE]	4	
11	MANUAL	1	
12	RENCH [2.5mm]	1	
13	RENCH [4mm]	1	
14	FRAME ASS'Y LEVEL CHECK BKT	2	

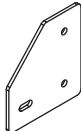
▼ 1	▼ 2	▼ 3,4	▼ 5,6,8	▼ 7	▼ 9
					
▼ 10	▼ 11	▼ 12	▼ 13	▼ 14	
					

4. INSTALL

4-1. HOW TO INSTALL_CABINET

*** Before assembling the product, place it in the location where you want to install it.**

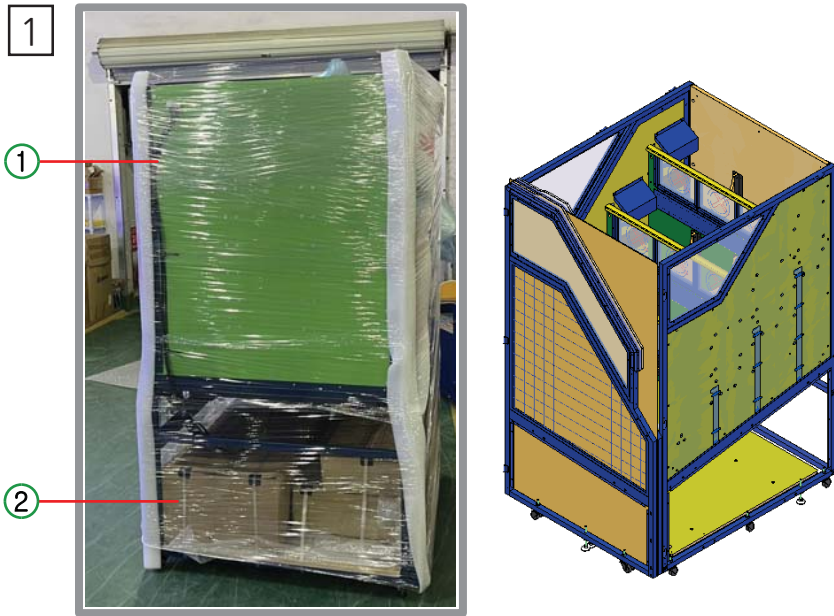

MAIN FRAME packing status

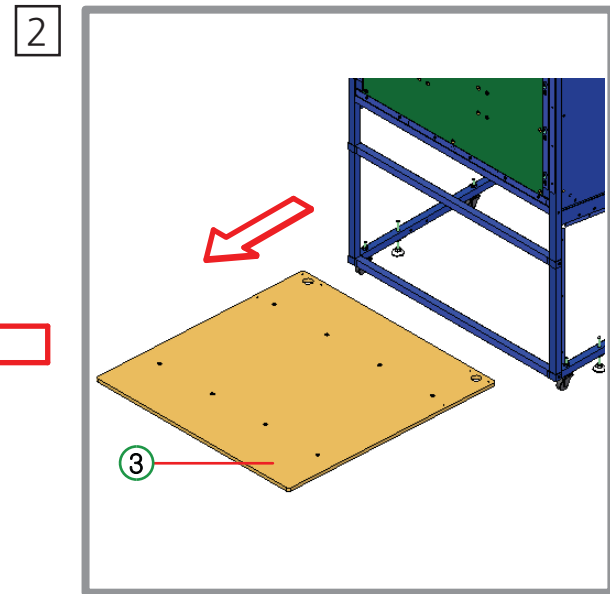
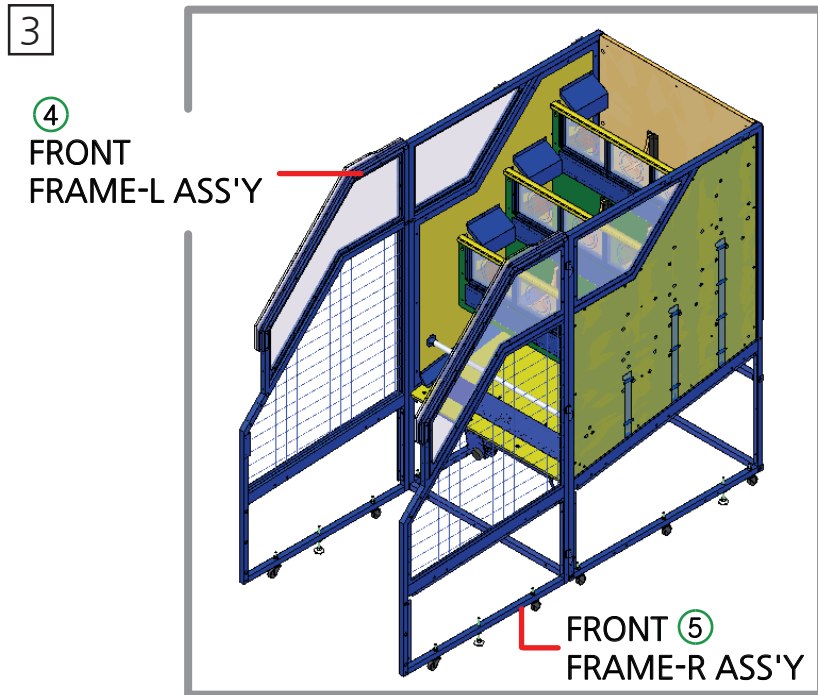
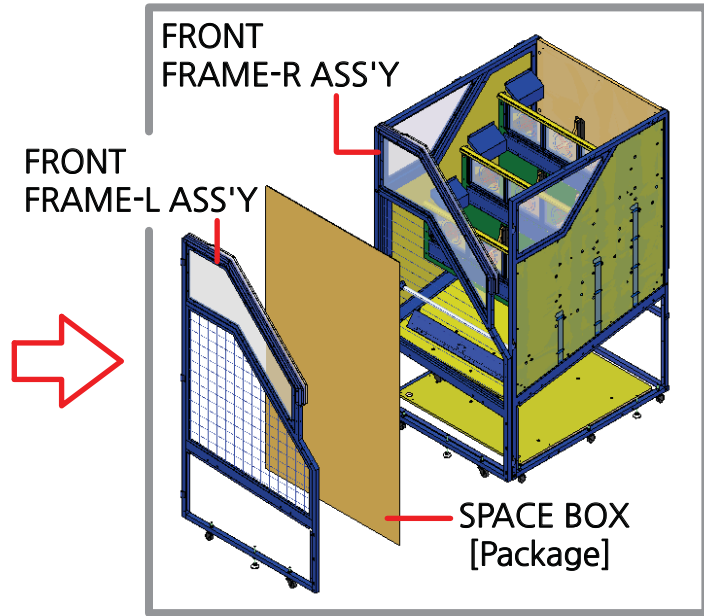

*** Pay attention to the L, R ASS'Y location and fix the HINGE**

NO	PROCESS	ITEM	Q'TY	
1	UNPACKING	FRONT FRAME + TARGET FRAME ASS'Y	1	
2	UNPACKING	ACCESSORY PACKING [Inside the MAIN FRAME]	1	
3	SEPARATION	FRONT BASE PANEL AND OTHERS	1	
4	ASSEMBLE	FRONT FRAME-L ASS'Y	1	Assemble using HINGE
5	ASSEMBLE	FRONT FRAME-R ASS'Y	1	Assemble using HINGE

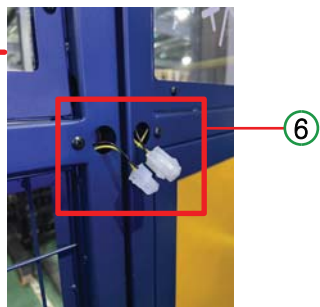
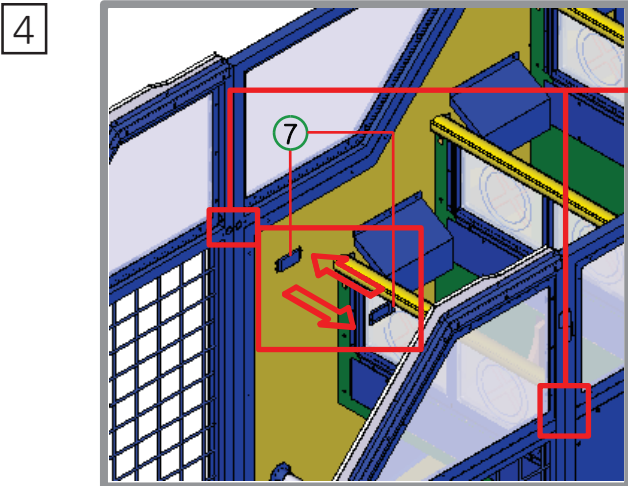

NO	PROCESS	ITEM	Q'TY	BOLT	SPEC	Q'TY
6	*CONNECTOR	CONNECTION (L,R)	2			
7	ASSEMBLE	DECO ACRYL HARNESS COVER BKT	2	SCREW TH	M4*16L	4

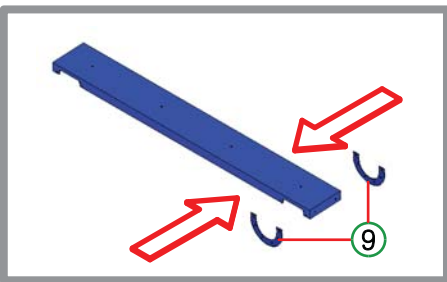
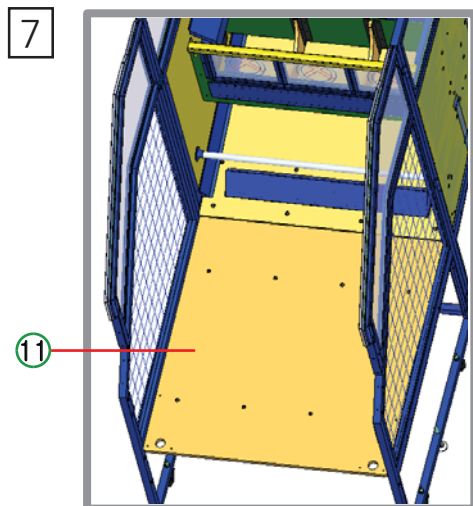
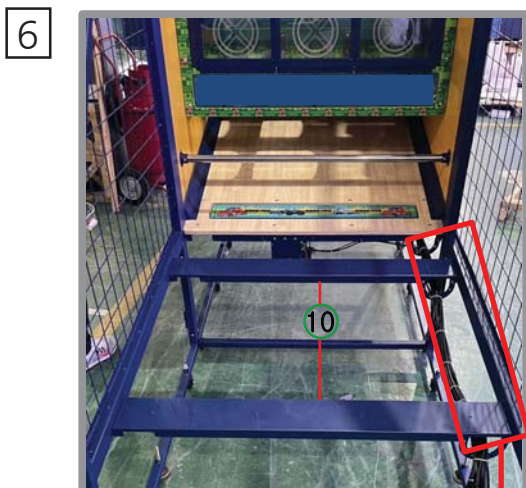
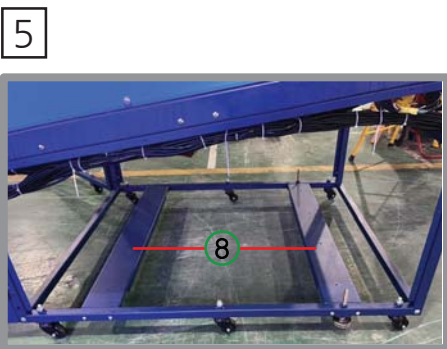

NO	PROCESS	ITEM	Q'TY	BOLT	SPEC	Q'TY
8	SEPARATION	BASE PANEL SUPPORT BKT	2	SCREW TH	M6*30L	8
9	ASSEMBLE	MAIN HARNESS COVER BKT	4	SCREW TH	M4*10L	8
10	ASSEMBLE	BASE PANEL SUPPORT BKT	2	SCREW TH	M6*30L	8
11	ASSEMBLE	FRONT BASE PANEL	1	SCREW TH	M6*30L	8

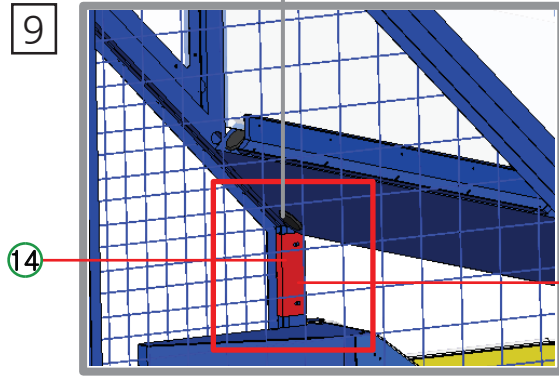
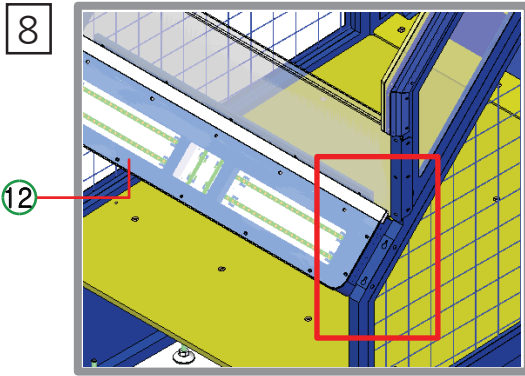

NO	PROCESS	ITEM	Q'TY	BOLT	SPEC	Q'TY
12	ASSEMBLE	PLAYER TURN LED ASS'Y	1	SEMS NI	M6*20L / M4*16L	4 / 4
13	ARRANGE	HARNESS				
14	ASSEMBLE	HARNESS COVER BKT (L,R)	2	SCREW TH	M4*10L	4

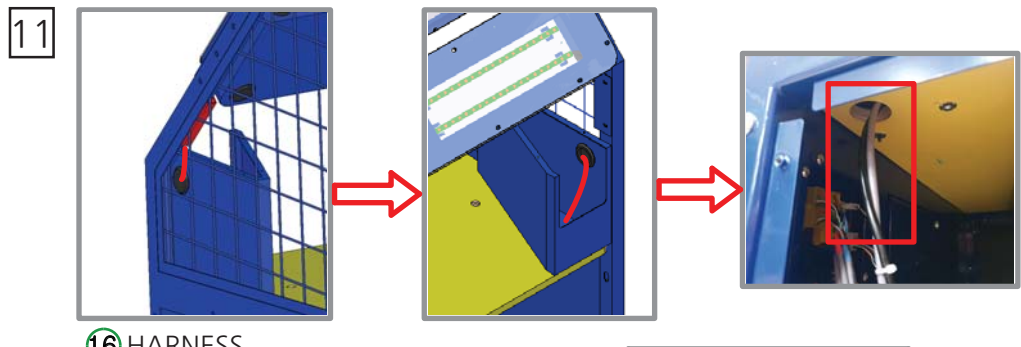
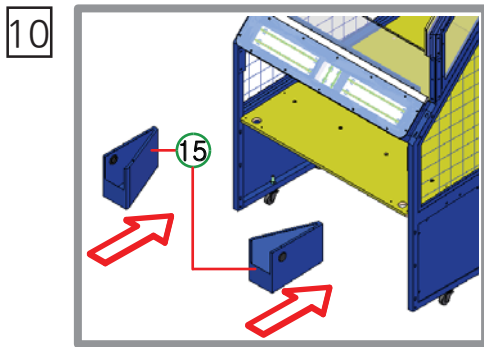

16 HARNESS



17 *CONNECTION
- After connecting, insert it into the rubber

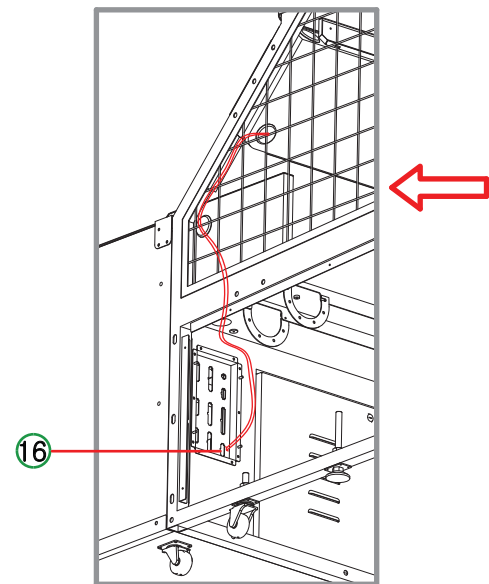

*WIRING ROUTE
[SPEAKER]

NO	PROCESS	ITEM	Q'TY	BOLT	SPEC	Q'TY
15	ASSEMBLE	BALL COLLECT BKT-L, R	2	SCREW TH	M4*16L	6
16	ARRANGE	HARNESS				
17	*CONNECTOR	CONNECTION (L,R)	2			

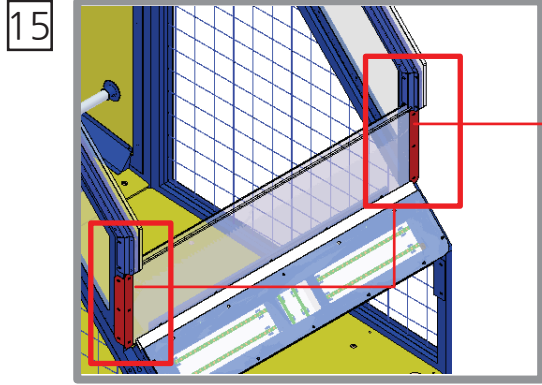
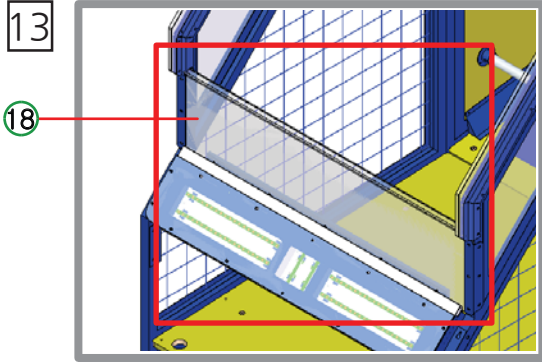

NO	PROCESS	ITEM	Q'TY	BOLT	SPEC	Q'TY
18	ASSEMBLE	BALL PROTECT PC	1	SCREW TH	M4*16L	6
19	ASSEMBLE	PC GUARD SUPPORT BKT	1	SCREW TH	M4*16L	5
20	ASSEMBLE	PC GUARD FIX BKT	2	SEMS NI	M4*16L	6

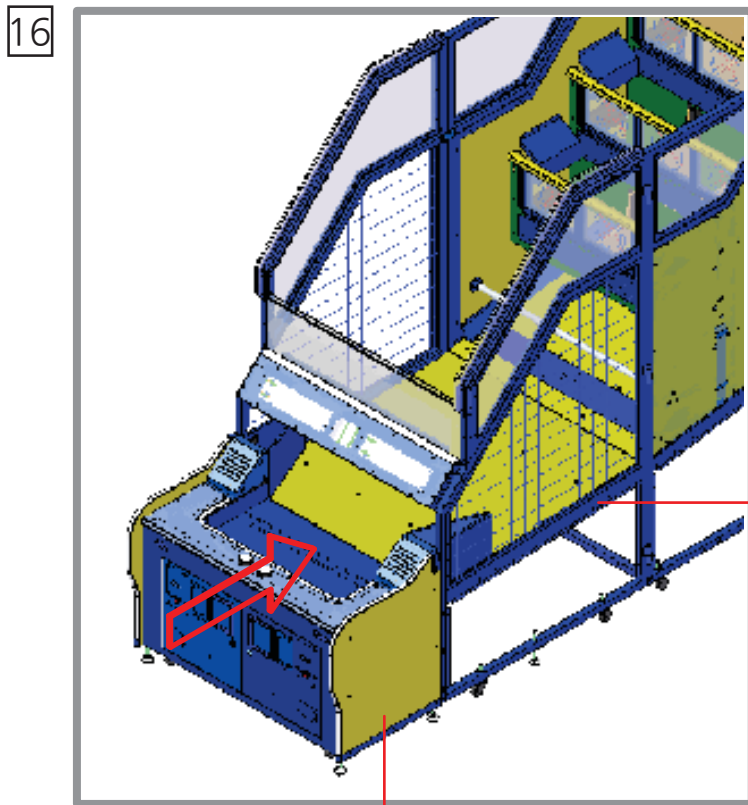

* Move the FRONT FRAME ASS'Y in the direction of the MAIN FRAME ASS'Y.

FRONT FRAME ASS'Y

FRONT CASE ASS'Y

[FRONT CASE] LEVEL ADJUSTER adjustment

17

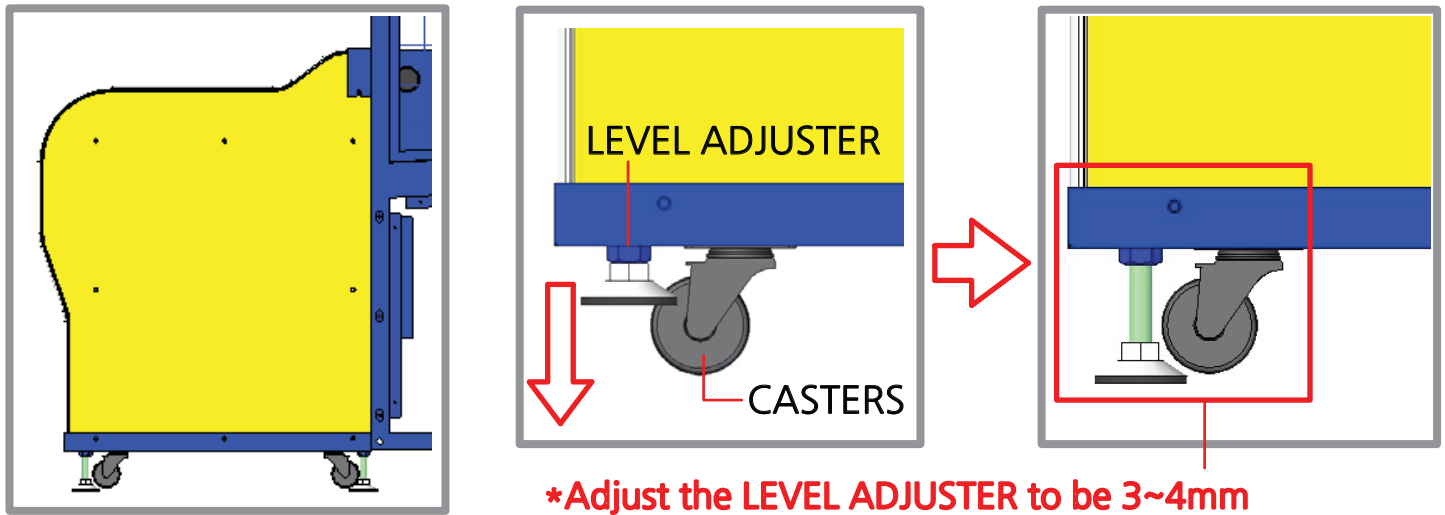

***Adjust the LEVEL ADJUSTER to be 3~4mm longer than the CASTERS.**

[FRONT FRAME & TARGET FRAME] LEVEL ADJUSTER adjustment

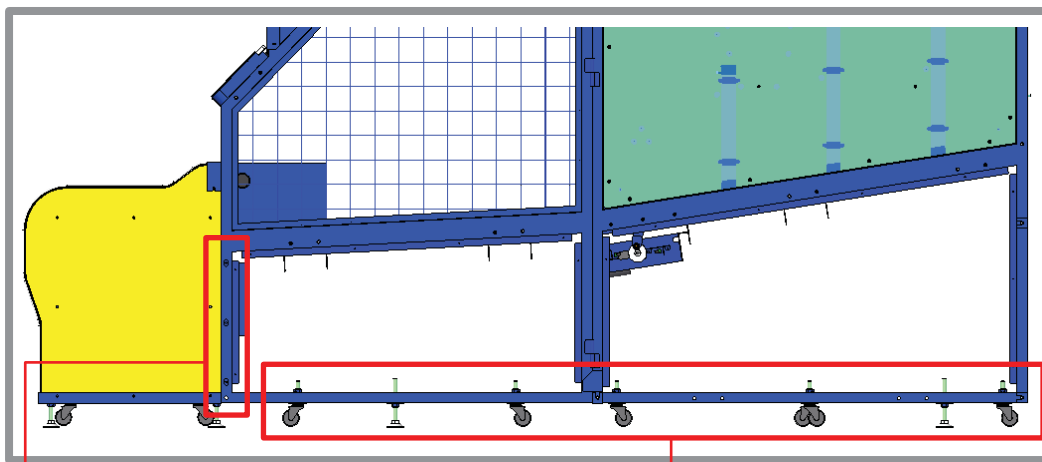

***See LEVEL ADJUSTER above.**
[At this time, adjust so that the long hole to connect to the FRONT CASE is visible.]

[LEVEL CHECK BKT] assembly

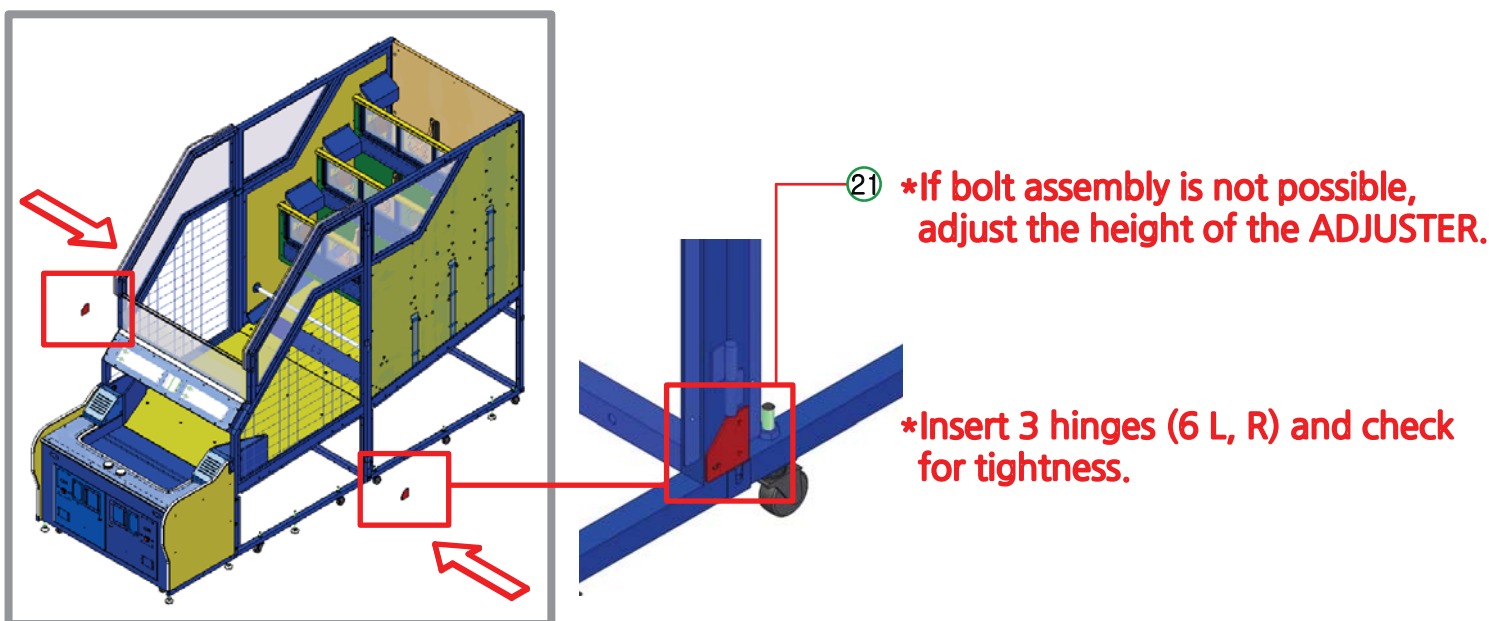

21 *If bolt assembly is not possible, adjust the height of the ADJUSTER.

***Insert 3 hinges (6 L, R) and check for tightness.**

NO	PROCESS	ITEM	Q'TY	BOLT	SPEC	Q'TY
21	ASSEMBLE	FRAME ASS'Y LEVEL CHECK BKT	2	SCREW TH	M4*16L	6

[FRONT & TARGET PART ASS'Y + FRONT CASE PART ASS'Y]

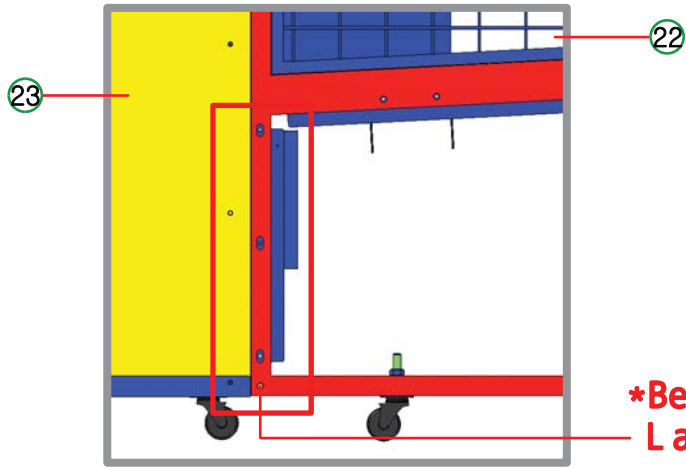

***Be sure to fix the M6 bolts after fixing the M8 bolts L and R at the bottom.**

NO	PROCESS	ITEM	Q'TY	BOLT	SPEC	Q'TY
22	ASSEMBLE	FRONT & TARGET PART ASS'Y	1			
23	ASSEMBLE	FRONT CASE PART ASS'Y	1	SEMS NI	M6*50L / M8*50L	6 / 2

18

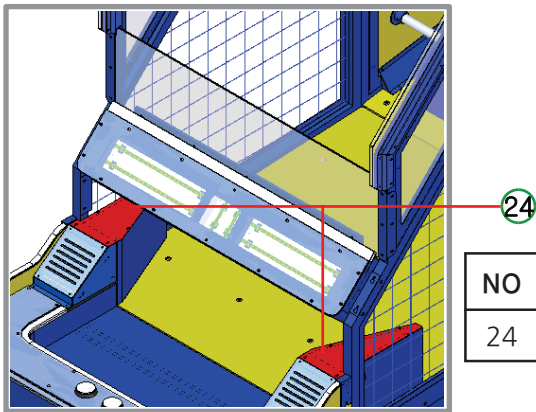

NO	PROCESS	ITEM	Q'TY	BOLT	SPEC	Q'TY
24	ASSEMBLE	BALL COLLECT COVER BKT-L, R	2	SCREW TH	M4*16L	12

19

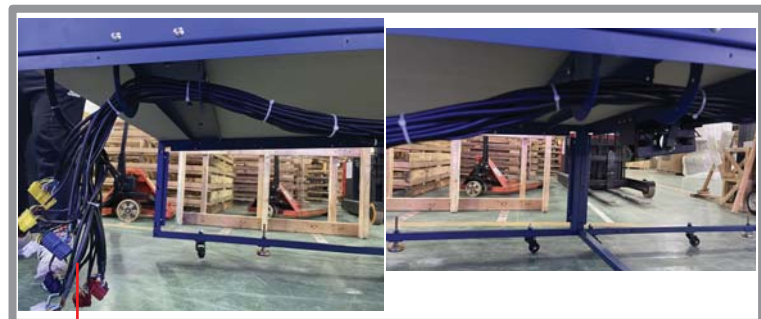
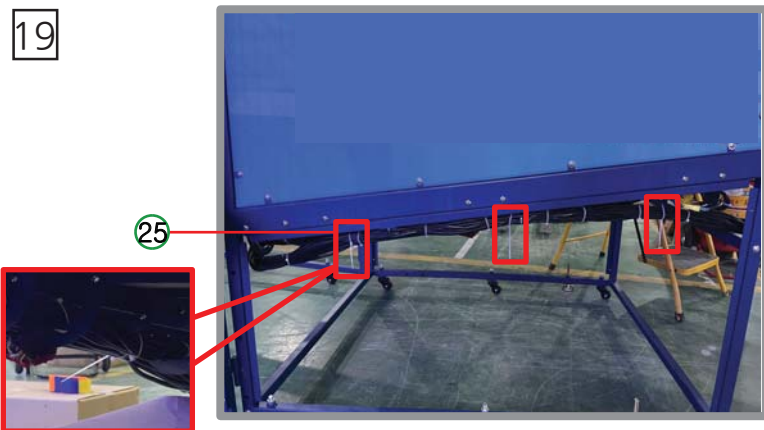

NO	PROCESS	ITEM	Q'TY	BOLT	SPEC	Q'TY
25	WIRING SEPARATION	HARNESS [Remove uncut ties]	1			
26	ARRANGE	HARNESS	1			

***Reuse after removing existing bolts**

20

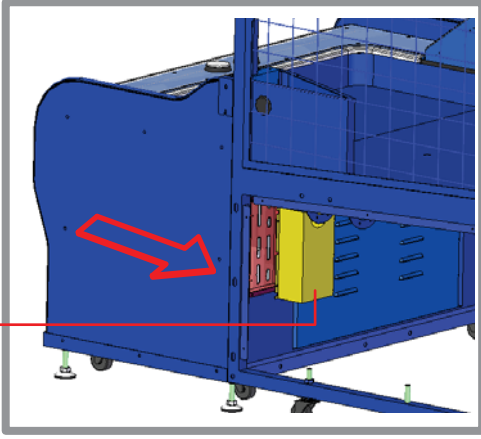

28 *CONNECTOR

27

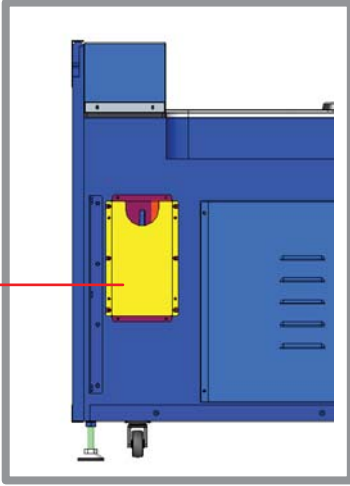

29

NO	PROCESS	ITEM	Q'TY	BOLT	SPEC	Q'TY
27	SEPARATION	FRONT CASE HARNESS COVER BKT	1	SCREW TH	M4*16L	6
28	*CONNECTOR	CONNECTION	1			
29	ASSEMBLE	FRONT CASE HARNESS COVER BKT	1	SCREW TH	M4*16L	6

21

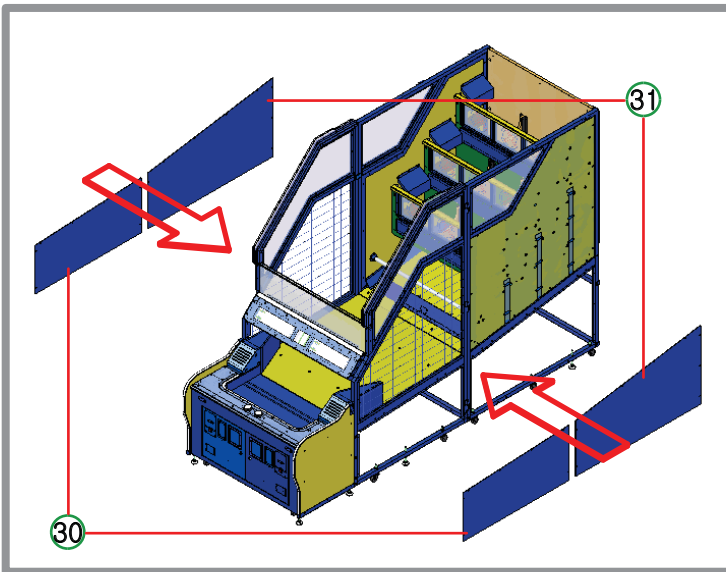

30

31

NO	PROCESS	ITEM	Q'TY	BOLT	SPEC	Q'TY
30	ASSEMBLE	CABINET FRONT SIDE DECO FOMAX-L,R	2	SEMS NI	M6*35L	16
31	ASSEMBLE	CABINET REAR SIDE DECO FOMAX-L,R	2	SEMS NI	M6*35L	18

4-2. HOW TO INSTALL BILLBOARD

[When installing the billboard, be sure to work with two people.]

22

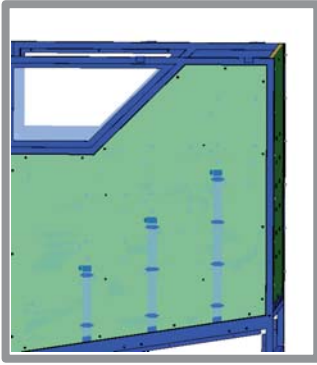

*If no BKT is shown, the hinge will be disconnected.

NO	PROCESS	ITEM	Q'TY	BOLT	SPEC	Q'TY
32	ASSEMBLE	BILLBOARD SIDE FRAME BKT ASS'Y L, R	2			
33	ASSEMBLE	BILLBOARD FRAME STOPPER BKT	2	SCREW TH	M4*16L	4

23

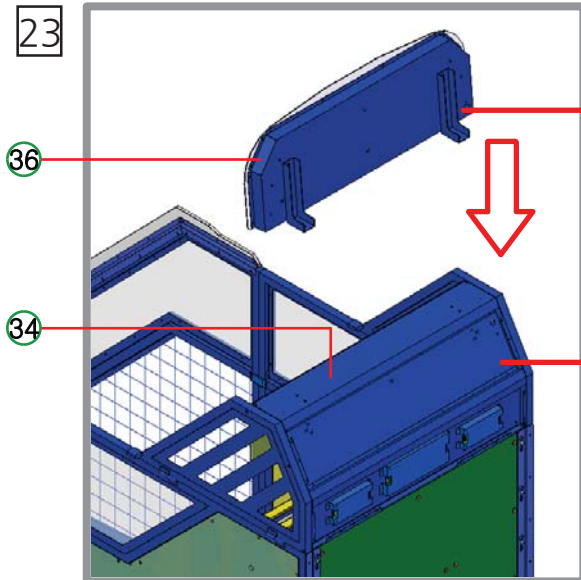

37 *CONNECTOR [BILLBOARD LIGHT]

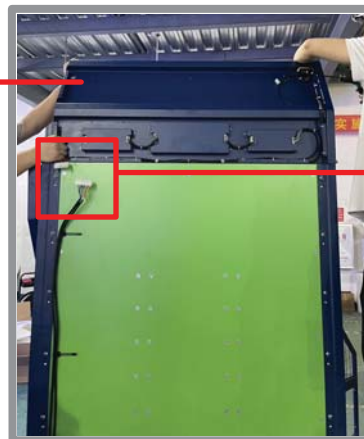



35 *CONNECTOR [BILLBOARD]

NO	PROCESS	ITEM	Q'TY	BOLT	SPEC	Q'TY
34	ASSEMBLE	BILLBOARD PART ASS'Y	1	SCREW TH	M6*50L	6
35	*CONNECTOR	CONNECTION				
36	ASSEMBLE	BILLBOARD LIGHT PART ASS'Y	1	SCREW TH	M6*20L	4
37	*CONNECTOR	CONNECTION				

5. SETUP SETTING

5-1. MACHINE SETUP

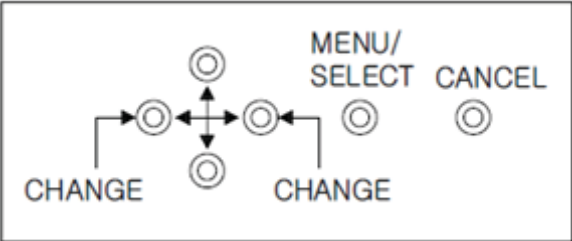
1.SETUP BUTTON LAYOUT

	<p>1) [↑↓] UP, DOWN : MENU UP/DOWN MOVE 2) [←→] LEFT, RIGHT : CHANGE SETTING VALUE 3) SELECT /MENU : SETUP MENU MODE, SELECT AND PERFORM 4) CANCEL : EXIT</p>
<div style="display: flex; justify-content: space-around; align-items: center;"> <div style="text-align: center;">  1P SERVICE / RESET </div> <div style="text-align: center;">  2P SERVICE / RESET </div> </div>	<p>NORMALLY SERVICE IN, IN CASE OF ERROR, USE THIS BUTTON TO CLEAR ERROR</p> <p>* EACH TIME SERVICE IN IS PRESSED ONCE, 1 CREDIT GOES UP</p>

- DIP SW. When changing the destination according to setting number 6, please proceed by selecting one of the items below.
 1. After changing the direction of DIP SW 6, run **FACTORY SETTING**.
 2. After changing the direction of DIP SW 6, turn the power OFF -> ON and run **FACTORY SETTING** if an error occurs.

DIP SW.	1	2	3	4	DESCRIPTION
 SW6	OFF	OFF	OFF	OFF	A
	OFF	ON	OFF	OFF	NJ
	OFF	OFF	ON	OFF	C
	OFF	OFF	OFF	OFF	(There are options that only apply to C)

OPERATING OPTIONS

PRESS MENU BUTTON. [MENU/SELECT BUTTON: ENTER]

PROGRAM SETTINGS	MODE FOR SETTING
CLEAR MODE	MODE FOR CLEAR
BOOKKEEPING	CHECKING GAME DATA
FACTORY SETTING	INITIALIZING TO FACTORY SETTING
TEST MODE	MODE FOR TESTING
EXIT	EXIT OPERATION OPTIONS

5-2. PROGRAM SETTINGS

LCD DISPLAY	DESCRIPTION	RANGE	DEFAULT
CREDIT / COIN [-> sub menu]	- SELECT COIN OR CARD AND FREE PLAY - SETTING NUMBER OF CREDIT PER COIN (The value stored here does not change even FACTORY SET)	=> (SUB MENU) (REFER TO BELOW TABLE #1)	
CREDIT / BILL [-> sub menu]	SETTING NUMBER OF CREDIT PERBILL (The value stored here does not change even FACTORY SET)	=> (SUB MENU) (REFER TO BELOW TABLE #2)	
PAYOUT SETTING [-> sub menu]	SETTING NUMBER OF TICKETS PER PLAY	=> (SUB MENU) (REFER TO BELOW TABLE #3)	
CHECK. TYPE	GAME TYPE (WHEN YOU SHOOT THE BALL INTO THE LAMPED TARGET) CHANGE - CHANGE DIRECTLY TO THAT PLAYER'S LAMP CLEAR - CHANGE TO RESET (NO LAMP) FIX - NO CHANGE (Only FIX in SINGLE)	"CHANGE" "CLEAR" "FIX"	CHANGE
*Not applicable for NJ version SELECT TIME	SINGLE, VERSUS SELECTION TIME	10 ~ 30 INCREASES BY 1 (UNIT = SEC)	20 SEC
PLAY TIME	TOTAL PLAY TIME	60 ~ 360 INCREASES BY 30 (UNIT = SEC)	120 SEC
TURN TIME	TURN PLAY TIME OFF : NO TIME LIMIT (If the player's GOAL is checked, the next player's turn)	OFF, 10 ~ 30 INCREASES BY 1 (UNIT = SEC)	15 SEC
DIFFICULTY	SINGLE PLAY DIFFICULTY (GAME TYPE = FIX)	"EASY" "NORMAL" "HARD"	NORMAL
TICKET VALUE	SELECT TICKET VALUE ➔ SETTING THE VALUE SET PER TICKET IN THE STORE EX) IF YOU SET "1/2" ➔ 1 PHYSICAL TICKET = 2 TICKETS IN GAME NONE : AUTOMATICALLY REDUCING TICKET COUNTS WITHOUT DISPENSING TICKETS	"NONE" "1/ 1" "1/ 2" "1/ 5" "1/10"	1/1
MERCY TICKET	SETTING FOR MERCY TICKET	0 ~ 20 INCREASES BY 1	0
FIXED TICKET	TICKET set regardless of game results (ONLY FOR C)	0 ~ 20 INCREASES BY 1	0
ATTRACT TIME	DEMO SOUND WAITING TIME SETTING OFF : NO USE	"OFF" 1 ~ 60 INCREASES BY 1 (UNIT = MIN)	5 MIN
ATTRACT VOLUME	SETTING DEMO SOUND ON/OFF AND	"OFF"	60

	VOLUME. "OFF" : NO SOUND "ON" 10 ~ 100 : SOUND VOLUME(%)	10 ~ 100 (INCREASES BY 10)	
SAVE AND EXIT	SAVE AND EXIT	BY PRESSING SELECT BUTTON, PERFORM BY MOVING THE CURSOR TO [YES] or [NO]	
CANCEL AND EXIT	CANCEL AND EXIT		

<TABLE #1>

<ul style="list-style-type: none"> ● PROGRAM SETTINGS -> PLAYS / COIN ◇ SETTING PLAYS(CREDITS) PER COIN 				
LCD DISPLAY	DESCRIPTION	RANGE	DEFAULT	
			NJ	A, C
PAYMENT TYPE	FREE PLAY OR COIN SETTING "FREE" - FREE PLAY "COINS" - INSERT COIN "CARD" - SWIPE CARD	"FREE" "COIN" "CARD"	"COIN"	
MINIMUM COIN	SETTING MINIMUM COIN NUMBER FOR PLAY	1 ~ 9 (INCREASES BY 1)	4	1
SAVE AND EXIT	SAVE AND EXIT (VALUE IS MAINTAINED EVEN AFTER FACTORY SET)	BY PRESSING SELECT BUTTON, PERFORM BY MOVING THE CURSOR TO [YES] or [NO]		
CANCEL AND EXIT	CANCEL AND EXIT			

<TABLE #2>

<ul style="list-style-type: none"> ● PROGRAM SETTINGS -> CREDIT / BILL ◇ SETTING CREDITS PER BILL NUMBER OF PLAYS INCREASES AS FOLLOWS IN CONJUNCTION WITH SIGNAL FROM BILL ACCEPTOR 			
LCD DISPLAY	DESCRIPTION	RANGE	DEFAULT
1 BILL	SETTING NUMBER OF CREDIT PER 1 BILL	1 ~ 200 (INCREASES BY 1)	1
2 BILL	SETTING NUMBER OF CREDIT PER 2 BILLS	1 ~ 200 (INCREASES BY 1)	2
5 BILL	SETTING NUMBER OF CREDIT PER 5 BILLS	1 ~ 200 (INCREASES BY 1)	5
10 BILL	SETTING NUMBER OF CREDIT PER 10 BILLS	1 ~ 200 (INCREASES BY 1)	10
20 BILL	SETTING NUMBER OF CREDIT PER 20 BILLS	1 ~ 200 (INCREASES BY 1)	20

50 BILL	SETTING NUMBER OF CREDIT PER 50 BILLS	1 ~ 200 (INCREASES BY 1)	50
100 BILL	SETTING NUMBER OF CREDIT PER 100 BILLS	1 ~ 200 (INCREASES BY 1)	100
SAVE AND EXIT	SAVE AND EXIT (VALUE IS MAINTAINED EVEN AFTER FACTORY SET)	BY PRESSING SELECT BUTTON, PERFORM BY MOVING THE CURSOR TO [YES] or [NO]	
CANCEL AND EXIT	CANCEL AND EXIT		

<TABLE #3>

● PROGRAM SETTINGS -> PAYOUT SETTING

REFER TO <TABLE #3-1> BELOW REGARDING EACH PRESET TYPE TABLE VALUE

LCD DISPLAY	DESCRIPTION	RANGE		DEFAULT
		A, NJ	C	
PRESET TYPE	TYPES OF PRESET (Marked as "USER" when modifying a separate item from the default value)	1 ~ 6 "USER"	1 ~ 3 "USER"	1
AVG. TICKET	Average payout shown by automatic calculation when change the setting (The decimal point is rounded off)			
P. WIN RATE	Player's winning rate	10 ~ 80 (INCREASES BY 10)		20%
WINNER TICKETS	SETTING WINNER'S TICKET	1 ~ 300 (INCREASES BY 1)		70
LOSER TICKETS	SETTING LOSER'S TICKET	1 ~ 300 (INCREASES BY 1)		20
DRAW TICKETS	SETTING DRAW TICKET	1 ~ 300 (INCREASES BY 1)		35
SAVE AND EXIT	SAVE AND EXIT	BY PRESSING SELECT BUTTON, PERFORM BY MOVING THE CURSOR TO [YES] or [NO]		
CANCEL AND EXIT	CANCEL AND EXIT			

<TABLE #3-1>

◎ PRESET TYPE TABLE (A, NJ)

- Select TYPE 1 to 6 or set individually
- Displayed as "USER" when modifying detailed items

1 \$	AVERAGE TICKET	P. WIN RATE	WINNER TICKETS	LOSER TICKETS	DRAW TICKETS
TYPE 1	36	20	70	20	35
TYPE 2	36	30	80	10	25
TYPE 3	35	30	70	10	30
TYPE 4	36	40	60	10	30
TYPE 5	35	40	50	20	30
TYPE 6	36	50	60	5	20

<TABLE #3-2>

◎ PRESET TYPE TABLE (C)

- Select TYPE 1 to 3 or set individually
- Displayed as "USER" when modifying detailed items

1 \$	AVERAGE TICKET	P. WIN RATE	WINNER TICKETS	LOSER TICKETS	DRAW TICKETS
TYPE 1	8	70	10	4	5
TYPE 2	9	80	10	4	6
TYPE 3	9	90	10	2	4

<TABLE #3-3>

◎ PRESET SET TABLE (A, NJ) 1.5\$, 2\$ Reference TABLE

	AVERAGE TICKET	P. WIN RATE	WINNER TICKETS	LOSER TICKETS	DRAW TICKETS
1.5 \$	54	20	105	30	53
	55	30	120	15	37
	53	30	105	15	45
	54	40	90	15	45
	53	40	75	30	45
	55	50	90	7	30

	AVERAGE TICKET	P. WIN RATE	WINNER TICKETS	LOSER TICKETS	DRAW TICKETS
2 \$	72	20	140	40	70
	73	30	160	20	50
	70	30	140	20	60
	72	40	120	20	60
	70	40	100	40	60
	73	50	120	10	40

5-3. CLEAR MODE

● CLEAR MODE		
✧ GAME DATA AND BOOKKEEPING DATA CAN BE DELETED		
LCD DISPLAY	DESCRIPTION	EXECUTION
CLEAR TICKETS	DELETE REMAINING TICKETS TO BE DISPENSED NOW	BY PRESSING SELECT BUTTON, PERFORM BY MOVING THE CURSOR TO [YES] or [NO]
CLEAR CREDITS	DELETE REMAINING CREDITS	
CLEAR DATA	DELETE ALL GAME DATA AND BOOKKEEPING DATA INCLUDING CREDITS AND TICKETS	
EXIT	EXIT	

5-4. BOOKKEEPING

● BOOKKEEPING	
LCD DISPLAY	DESCRIPTION
1P : 1 Player 2P : 2 Player TOTAL : 1P, 2P TOTAL	
- COIN IN - 1P: 0 2P: 0 TOTAL: 0	NUMBER OF COIN IN (1P, 2P, TOTAL)
- BILL IN - 1P: 0 2P: 0 TOTAL: 0	NUMBER OF BILL IN (1P, 2P, TOTAL)
- SERVICE IN - 1P: 0 2P: 0 TOTAL: 0	NUMBER OF SERVICE IN AND PLAYS (1P, 2P, TOTAL) (SERVICE BUTTON INCREASES BY 1 CREDIT)
- TICKET OUT - 1P: 0 2P: 0 TOTAL: 0	NUMBER OF TOTAL TICKET OUT (1P, 2P, TOTAL)
- GAME PLAY - SINGLE : 0 VERSUS: 0 TOTAL: 0	NUMBER OF TOTAL GAME PLAY (SINGLE, VERSUS, TOTAL)
- SINGLE RESULT - P. WIN: 0 C. WIN: 0 DRAW: 0	RESULT OF SINGLE PLAY
- VER. INFO 1 - TIC SHAQ TOE INT-A x.xx ____ - ____	SHOW BASIC VERSION INFORMATION - GAME NAME - MAINBOARD PROGRAM VERSION - MAINBOARD PROGRAM MODIFICATION DATE
- VER. INFO 2 - SOUND : x.x	VERSION INFORMATION - SOUND VERSION
CANCEL BUTTON : EXIT	

- **FACTORY-SETTING** INITIALIZE TO FACTORY SETTING VALUE (DELETE ALL DATA AND SET TO GAME DEFAULT VALUE)

★ **COIN, BILL SETTINGS AND SHOOTING SPEED CAN NOT BE INITIALIZED AGAINST FACTORY SETTING**

LCD DISPLAY (PERFORM)	LCD DISPLAY (PERFORM)
FACTORY-SETTING ARE YOU SURE? YES or [<u>NO</u>] PERFORM BY MOVING THE CURSOR	FACTORY-SETTING ARE YOU SURE? YES or [<u>NO</u>] PERFORM BY MOVING THE CURSOR

























5-5. TEST MODE

TEST MODE		
LCD DISPLAY	COMPOSITION	DESCRIPTION
INPUT TEST	[=>] (See Table #4 below)	ENTER INPUT TEST MODE 1P GAME BTN, 2P GAME BTN : 1P, 2P GAME BUTTON 1P COIN SEN, 2P COIN SEN : 1P, 2P COIN SENSOR 1P BILL SEN, 2P BILL SEN : 1P, 2P BILL SENSOR 1P TICKET BTN, 1P TICKET SEN : 1P TICKET BUTTON, SENSOR 2P TICKET BTN, 2P TICKET SEN : 2P TICKET BUTTON, SENSOR 1P SERVICE, 2P SERVICE : 1P, 2P SERVICE BUTTON UP, DOWN, LEFT, RIGHT, SELECT, CANCEL BUTTON : SETUP BUTTON INPUT STATUS PER EACH NUMBER AND EACH IO PORT (INPUT 0, 1, 4, 5) 0: 000000000000000000 1: 000000000000000000 4: 000000000000000000 5: 000000000000000000
LED & FND	"OFF" "STEP_1" "STEP_2" "STEP_3" "ON" "ON/OFF"	LAMP, FND, LED TEST EVERY TIME YOU PRESS SELECT BUTTON, EACH STEP IS EXECUTED OFF : ALL OFF STEP_1 : DISPLAY LAMP, FND, LED ORDER PATTERN (RGB ORDER) STEP_2 : DISPLAY LED ORDER PATTERN (BIT RGB ORDER) STEP_3 : DISPLAY LAMP ORDER PATTERN (BIT WHITE ORDER) ON : ALL ON ON/OFF : ALL ON / OFF REPETITIVE MOTION

BALL BREAK	OFF OPEN CLOSE AUTO	<p>BALL BRAKE MOTOR TEST ◎ AFTER SELECTING WITH THE LEFT AND RIGHT BUTTONS, PRESS THE SELECT BUTTON TO OPERATE</p> <p>ONE PLAYER BUTTON OPEN, OFF OPERATION TWO PLAYER BUTTON CLOSE, OFF OPERATION</p> <p>RED TURN FND 3-DIGIT MOTOR TEST STATUS DISPLAY FND [■■■] : [On], [Off]</p> <p>BLUE TURN FND 3-DIGIT MOTOR ENCODER SENSOR STATUS DISPLAY FND [■□□] : OPEN SENSOR ON (0, 1) FND [□□■] : CLOSE SENSOR ON (0, 1)</p>
COIN	OFF ON	<p>COIN TEST ◎ 1P, 2P ON, OFF OPERATION BY PRESSING THE SELECT BUTTON</p> <p>ONE PLAYER BUTTON 1P INDIVIDUAL ON, OFF OPERATION TWO PLAYER BUTTON 2P INDIVIDUAL ON, OFF OPERATION</p> <p>TURN FND 3-DIGIT OPERATE, SENSOR, COUNTER STATUS DISPLAY FND [■□□] : DISPLAY ON/OFF (0:OFF, 1:ON) FND [□■□] : SENSOR CHECK (0:OFF, 1:ON) FND [□□■] : SENSOR CHECK COUNTER (0 ~ 9)</p>
BILL	OFF ON	<p>BILL ACCEPTOR TEST ◎ 1P, 2P ON, OFF OPERATION BY PRESSING THE SELECT BUTTON</p> <p>ONE PLAYER BUTTON 1P INDIVIDUAL ON, OFF OPERATION TWO PLAYER BUTTON 2P INDIVIDUAL ON, OFF OPERATION</p> <p>TURN FND 3-DIGIT OPERATE, SENSOR, COUNTER STATUS DISPLAY FND [■□□] : DISPLAY ON/OFF (0:OFF, 1:ON) FND [□■□] : SENSOR CHECK (0:OFF, 1:ON) FND [□□■] : SENSOR CHECK COUNTER (0 ~ 9)</p>
TICKET	"OFF" "1P" "2P"	<p>TICKET TEST (DISPENSE 3 TICKETS) ◎ 1P, 2P ON, OFF OPERATION BY PRESSING THE SELECT BUTTON</p> <p>ONE PLAYER BUTTON OPEN, OFF OPERATION TWO PLAYER BUTTON CLOSE, OFF OPERATION</p> <p>TURN FND 3-DIGIT OPERATE, SENSOR, COUNTER STATUS DISPLAY FND [■□□] : DISPLAY ON/OFF (0:OFF, 1:ON) FND [□■□] : SENSOR CHECK (0:OFF, 1:ON) FND [□□■] : SENSOR CHECK COUNTER (0 ~ 9)</p>

COUNTER	“COIN” “TICKET”	<p>COUNTER MACHINE TEST</p> <p>◎ AFTER SELECTING A TYPE WITH THE LEFT AND RIGHT BUTTONS, PRESS THE SELECT BUTTON TO TEST (OR 1P, 2P INDIVIDUAL ON/OFF ACTION WITH SINGLE, VERSUS BUTTON)</p> <p>ONE PLAYER BUTTON 1P COIN, TICKET OPERATION TWO PLAYER BUTTON 1P COIN, TICKET OPERATION</p> <p>RED TURN FND 3-DIGIT MOTOR TEST STATUS DISPLAY FND [■■■] : [On], [Off]</p> <p>BLUE TURN FND 3-DIGIT COIN SENSOR STATUS DISPLAY FND [■■■] : COUNTER (0 ~ 999)</p>
SOUND	“OFF” “CH.0” “PLAY”	<p>SOUND TEST</p> <p>◎ AFTER SELECTING THE TYPE WITH THE LEFT AND RIGHT BUTTONS, TEST WITH THE SELECT BUTTON (PLAY, STOP)</p> <ul style="list-style-type: none"> - STOP PLAYING SOUND - EACH PLAYER SPEAKER (1P LEFT, 2P RIGHT) TEST - PLAY FULL SOUND LIST
EXIT		EXIT FROM TEST MODE

<TABLE #4>

CENTER TIME FND	DESCRIPTION	CENTER TIME FND	DESCRIPTION
	CHECK SENSOR 1		CHECK SENSOR 2
	CHECK SENSOR 3		CHECK SENSOR 4
	CHECK SENSOR 5		CHECK SENSOR 6
	CHECK SENSOR 7		CHECK SENSOR 8
	CHECK SENSOR 9		BALL BREAK OPEN SENSOR
	BALL BREAK CLOSE SENSOR		1P COIN SENSOR
	2P COIN SENSOR		1P BILL SENSOR
	2P BILL SENSOR		1P TICKET SENSOR
	2P TICKET SENSOR		ONE PLAYER BUTTON
	TWO PLAYERS BUTTON		1P TICKET BUTTON
	2P TICKET BUTTON		1P SERVICE BUTTON
	2P SERVICE BUTTON		

5-6. ERROR CODE

“TICKET ERROR”, DOES NOT STOP GAMEPLAY, ONLY “HELP” MESSAGE IS DISPLAYED.

ERROR CODE	ERROR TYPE	DESCRIPTION	CHECK POINT
ER.01	BY REGION	SETUP SAVE DATA AND LOCATION OF MAIN PCB DIP SW ARE INCORRECT	1. CHECK MAIN PCB DIP SW LOCATION 2. Execute FACTORY SET 3. IF THE PROBLEM PERSISTS, REPLACE THE MOTHERBOARD
ER.02	SYSTEM	SETUP SAVE DATA PROBLEM	1. CHECK AND SAVE SETUP SETTINGS 2. DO FASTORY SET 3. CHECK POWER ON/OFF 4. IF THE PROBLEM PERSISTS, REPLACE THE MAIN BOARD
ER.03		GAME SAVE DATA PROBLEM	1. SETUP IN CLEAR MODE CLEAR DATA 2. CHECK POWER ON/OFF 3. IF THE PROBLEM PERSISTS, REPLACE THE MAIN BOARD
ER.04		SOUND FLASH AND DATA PROBLEM	1. REPLACE SOUND FLASH 2. CONFIRM NORMAL INSERTION OF SOUND FLASH 3. IF THE PROBLEM PERSISTS, REPLACE THE SOUND FLASH
ER.11	COIN MACHINE	PLAYER COIN SENSOR SIGNAL STILL PRESENT	CHECK THE PROBLEM PLAYER COIN MACHINE
ER.12	BILL ACCEPTOR	PLAYER BILL SENSOR SIGNAL STILL PRESENT	CHECK THE PROBLEM PLAYER BILL ACCEPTOR
ER.21	BALL BRAKE	BALL BRAKE OPEN SENSOR NO SIGNAL	1. CHECK MOTOR OPERATION STATUS 2. CHECK OPEN SENSOR INPUT STATUS
ER.22		BALL BRAKE CLOSE SENSOR NO SIGNAL	1. CHECK MOTOR OPERATION STATUS 2. CHECK CLOSE SENSOR INPUT STATUS
Er.31	CHECKER [7 8 9] [4 5 6] [1 2 3] CORRESPONDING LOCATION LED BLINKS	SENSOR 1 SIGNAL STILL ON	1. CHECK SENSOR STATUS
Er.32		SENSOR 2 SIGNAL STILL ON	
Er.33		SENSOR 3 SIGNAL STILL ON	
Er.34		SENSOR 4 SIGNAL STILL ON	
Er.35		SENSOR 5 SIGNAL STILL ON	
Er.36		SENSOR 6 SIGNAL STILL ON	
Er.37		SENSOR 7 SIGNAL STILL ON	
Er.38		SENSOR 8 SIGNAL STILL ON	
Er.39		SENSOR 9 SIGNAL STILL ON	
HEP (DISPLAY AT TICKET FND)	TICKET ERROR	NO TICKET	1. CHECK TICKET 2. CHECK TICKET MOTOR OPERATION 3. CHECK TICKET EJECT SENSOR
※ BASICALLY, THE ERROR CODE IS DISPLAYED ON THE SETUP LCD AND GAME TIME FND			

- ERROR CODE ERROR DETECTION METHOD

ERROR CODE	ERROR TYPE	DESCRIPTION	CHECK POINT
ER.01	BY REGION	LOCATION MISMATCH BETWEEN SETUP SAVE DATA AND MAIN PCB DIP SW	CHECK SETUP SAVE DATA AND DIP SW POSITION OF MAIN PCB
ER.02	SYSTEM	SETUP SAVE DATA PROBLEM	TURN ON THE POWER AND CHECK THE BACKUP MEMORY RELATED TO THE MAIN BOARD SETUP
ER.03		GAME SAVE DATA PROBLEM	TURN ON THE POWER AND CHECK THE BACKUP MEMORY RELATED TO THE MAIN BOARD GAME
ER.04		SOUND FLASH AND DATA PROBLEM	AFTER TURNING OFF THE POWER, CHECK THE INSTALLATION OF SOUND FLASH
ER.11	COIN MACHINE	PLAYER COIN SENSOR SIGNAL STILL PRESENT	WHEN INHIBIT IS ON, SIGNAL IS CONTINUOUSLY PRESENT FOR MORE THAN 2 SECONDS
ER.12	BILL ACCEPTOR	PLAYER BILL SENSOR SIGNAL STILL PRESENT	WHEN INHIBIT IS ON, SIGNAL IS CONTINUOUSLY PRESENT FOR MORE THAN 2 SECONDS
ER.21	BALL BRAKE	BALL BRAKE OPEN SENSOR NO SIGNAL	NO OPEN SENSOR SIGNAL FOR 5 SECONDS DURING MOTOR OPERATION
ER.22		BALL BRAKE CLOSE SENSOR NO SIGNAL	NO CLOSE SENSOR SIGNAL FOR 5 SECONDS DURING MOTOR OPERATION
ER.31	CHECKER [7 8 9] [4 5 6] [1 2 3] CORRESPONDING LOCATION LED BLINKS	SENSOR 1 SIGNAL STILL ON	SENSOR SIGNAL ON FOR MORE THAN 2 SECONDS
ER.32		SENSOR 2 SIGNAL STILL ON	SENSOR SIGNAL ON FOR MORE THAN 2 SECONDS
ER.33		SENSOR 3 SIGNAL STILL ON	SENSOR SIGNAL ON FOR MORE THAN 2 SECONDS
ER.34		SENSOR 4 SIGNAL STILL ON	SENSOR SIGNAL ON FOR MORE THAN 2 SECONDS
ER.35		SENSOR 5 SIGNAL STILL ON	SENSOR SIGNAL ON FOR MORE THAN 2 SECONDS
ER.36		SENSOR 6 SIGNAL STILL ON	SENSOR SIGNAL ON FOR MORE THAN 2 SECONDS
ER.37		SENSOR 7 SIGNAL STILL ON	SENSOR SIGNAL ON FOR MORE THAN 2 SECONDS
ER.38		SENSOR 8 SIGNAL STILL ON	SENSOR SIGNAL ON FOR MORE THAN 2 SECONDS
ER.39		SENSOR 9 SIGNAL STILL ON	SENSOR SIGNAL ON FOR MORE THAN 2 SECONDS
HEP (DISPLAY AT TICKET FND)	TICKET ERROR	NO TICKET	1. CHECK YOUR TICKET 2. CHECK TICKET MOTOR OPERATION 3. CHECK TICKET EJECT SENSOR

6. MAINTENANCE

6-1. Precautions for turning on the power

: When it is newly turned on after power is turned off, the power must be turned on after 10 seconds.

6-2. When installing the device

: Connect the device with a ground outlet to which fg is connected.

6-3. Main board management

: Dust removal on the main board will be carried out once a month.

6-4. Basic product management : Clean it regularly

6-5. This product should only be used for indoor use

7. EXPLODE VIEW

7-1. MAIN CABINET PART

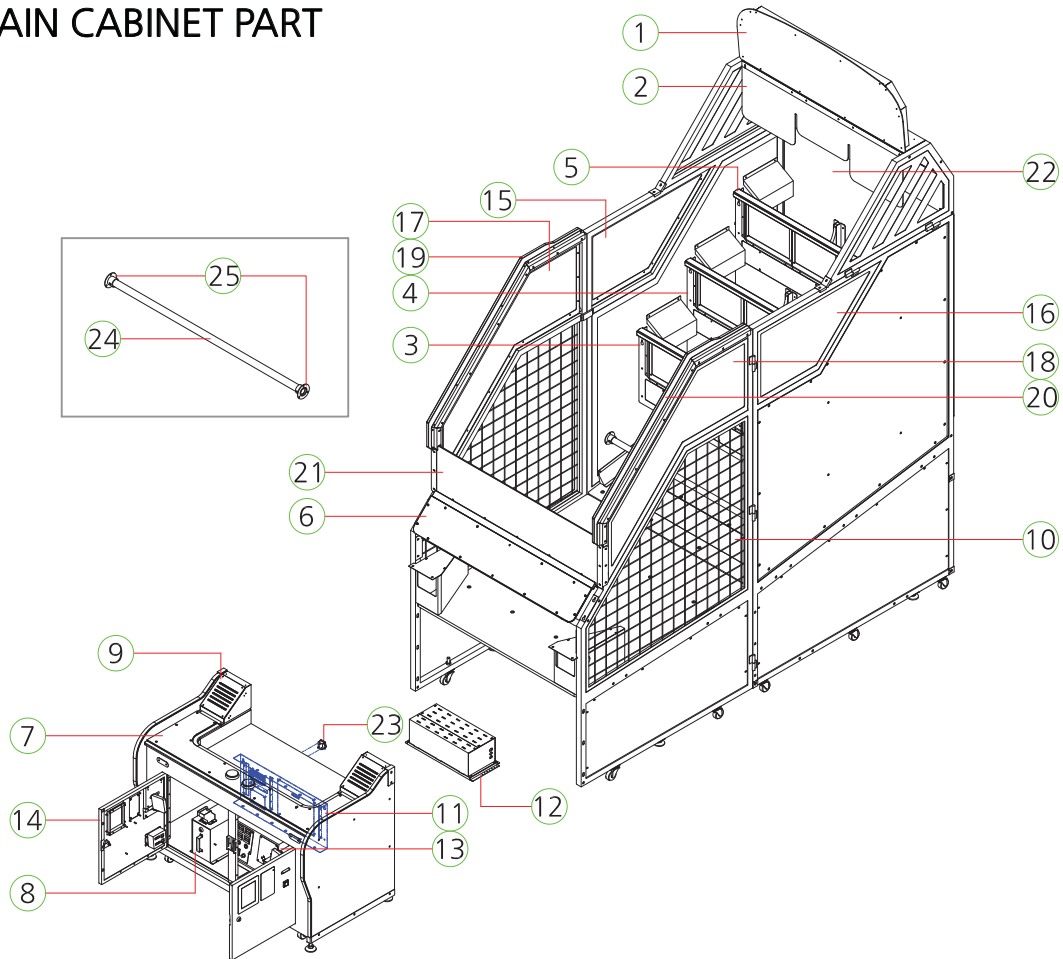

NO.	PART NAME	SPEC.	QUANTITY	CODE NO.
1	BILLBOARD LIGHT PART	-	1	-
2	BILLBOARD PART	-	1	-
3	TARGET TOTAL PART-A PART	-	1	-
4	TARGET TOTAL PART-B PART	-	1	-
5	TARGET TOTAL PART-C PART	-	1	-
6	PLAYER TURN LED PART	-	1	-
7	FRONT BUTTON PART	-	1	-
8	COIN BOX PART	-	1	-
9	SPEAKER PART	-	2	-
10	BALL BLOCK PART	-	1	-
11	MAIN BOARD PART	-	1	-
12	POWER SMPS PART	-	1	-
13	CONTROL PANEL PART	-	1	-
14	FRONT CASE DOOR PART	-	2	-
15	TARGET MAIN FRAME-L ACRYL	ACRYL-12T	1	MTTO0ACR018
16	TARGET MAIN FRAME-R ACRYL	ACRYL-12T	1	MTTO0ACR018
17	FRONT MAIN FRAME-L ACRYL	ACRYL-12T	1	MTTO0ACR015
18	FRONT MAIN FRAME-R ACRYL	ACRYL-12T	1	MTTO0ACR015
19	FRONT MAIN FRAME LINEAR ACRYL PART-L	ACRYL-12T	1	MTTO0ACR005
20	FRONT MAIN FRAME LINEAR ACRYL PART-R	ACRYL-12T	1	MTTO0ACR005
21	BALL PROTECT PC	PC-5T	1	MTTO0ACR001
22	BACKBOARD COVER PET	PET-1.0T	1	MTTO0ACR010
23	AC INPUT ASS'Y	DAC-13H, WITH FUSE 10A_2EA	1	AELE0FUS002
24	BALL BLOCK SUPPORT PIPE	STS-304	1	MTTO0MEP113
25	BALL BLOCK PIPE FIX BKT ASS'Y	SPCC-1.6T / PIPE	2	MTTO0MEP114

7-2. BILLBOARD LIGHT PART

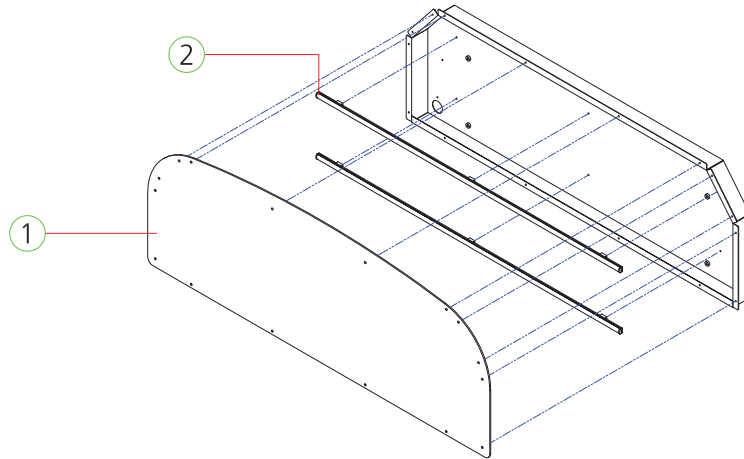

NO.	PART NAME	SPEC.	QUANTITY	CODE NO.
1	BILLBOARD PC	PC-3.0T	1	MTTO0ACR012
2	LED BAR 12V ASS'Y	910mm	2	AZZZ0PCB128

7-3. BILLBOARD PART

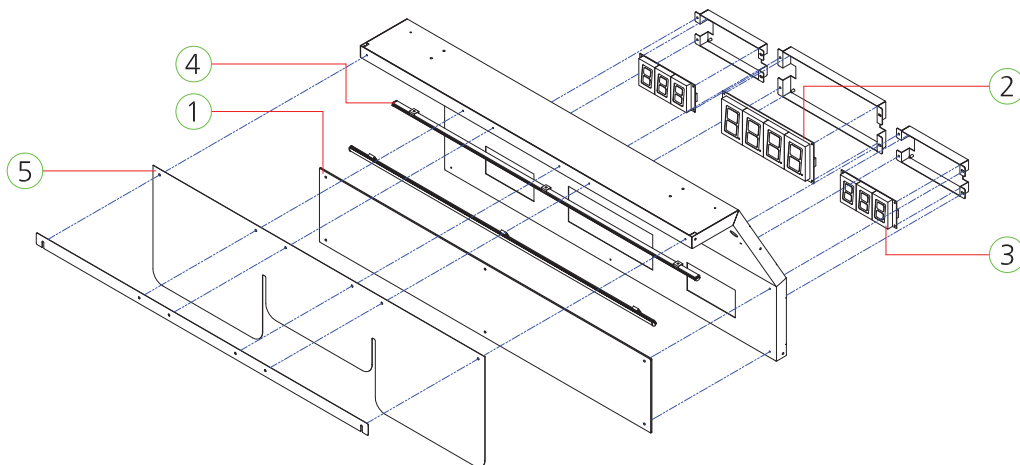

NO.	PART NAME	SPEC.	QUANTITY	CODE NO.
1	BILLBOARD FND COVER ACRYL	ACRYL-3.0t	1	MTTO0ACR011
2	FND PCB ASS'Y	6390-4(STRAIGHT)	1	AFND0PCB011
3	FND PCB ASS'Y	4870-3(STRAIGHT)	2	AFND0PCB027
4	LED BAR 12V ASS'Y	910mm	2	AZZZ0PCB128
5	BILLBOARD COVER CLOTH	-	1	MTTO0ACR021

7-4. TARGET TOTAL PART-A PART [A,B,C PART Identical parts applied]

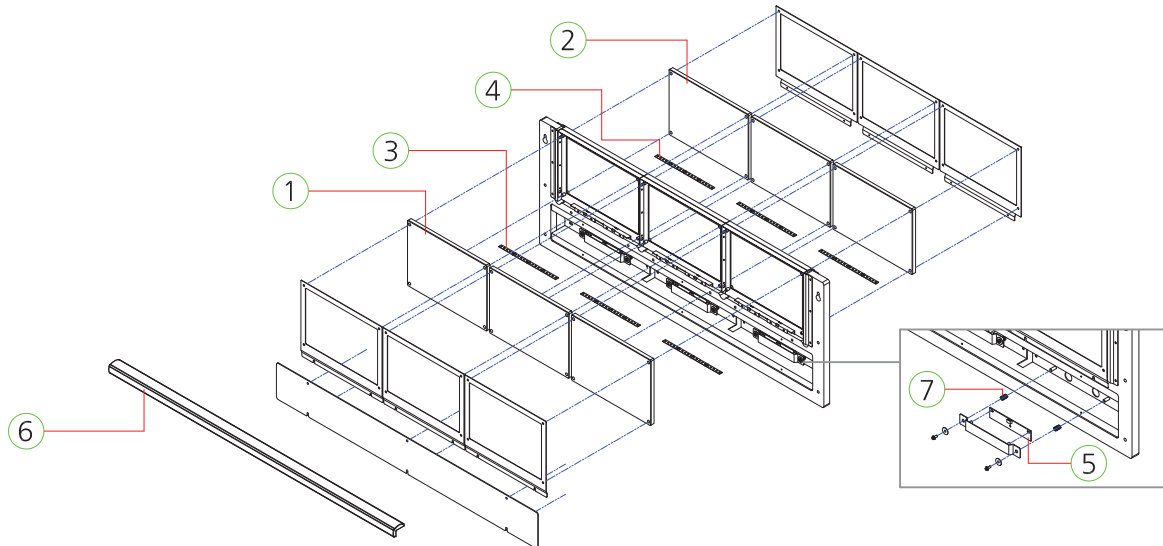

NO.	PART NAME	SPEC.	QUANTITY	CODE NO.
1	TARGET ACRYL-O	ACRYL-12T	3	MTTO0ACR008
2	TARGET ACRYL-X	ACRYL-12T	3	MTTO0ACR009
3	FLEX_5050_RGB_200_NWP_L_12	T5050 TOP300,12	3	MELE0LED128
4	FLEX_3528_RED_200_NWP_L_12	TOP300, 12	3	MELE0LED069
5	BALL SENSOR PCB ASS'Y	38Khz 2Point	3	ATTO0PCB001
6	BALL SAFE GUIARD SPONGE	YELLOW, 1m	1	MTTO0RUB002
7	GOALPOST ACRYL TENSION SPRING	-	2	MSBS0SPR001

7-5. PLAYER TURN LED PART

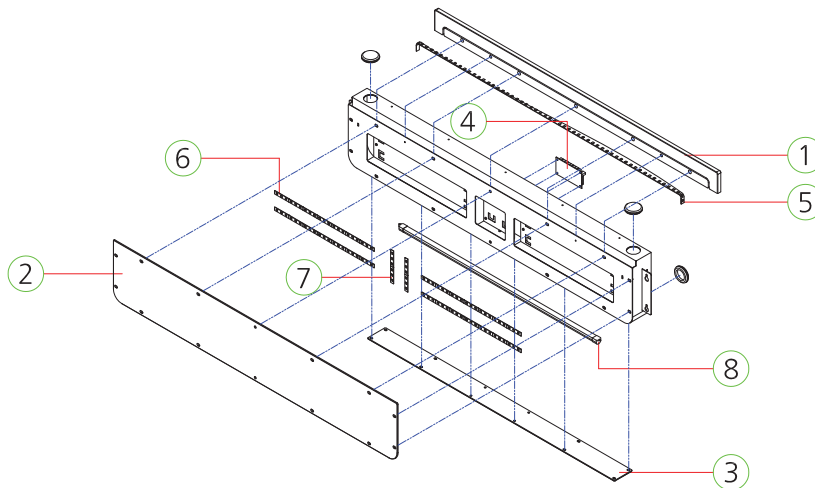

NO.	PART NAME	SPEC.	QUANTITY	CODE NO.
1	PLAYER TURN TOP LINE ACRYL	ACRYL-12T	1	MTTO0ACR007
2	PLAYER TURN LED COVER ACRYL	ACRYL-3t	1	MTTO0ACR023
3	PLAYER TURN BAR LED BOTTOM ACRYL	ACRYL-3.0t	1	MTTO0ACR006
4	TST FND EXT IO PCB ASS'Y	90*50 16BIT EXT	1	ATTO0PCB002
5	FLEX_5050_RGB_1000_NWP_L_60	T5050 TOP300, 60	1	MELE0LED126
6	FLEX_5050_WHITE_350_NWP_L_21	T5050 TOP300, 21	4	MELE0LED129
7	FLEX_5050_WHITE_100_NWP_L_9	T5050 TOP300, 6	2	MELE0LED130
8	LED BAR 12V ASS'Y	710mm	1	AZZZ0PCB165

7-6. FRONT BUTTON PART

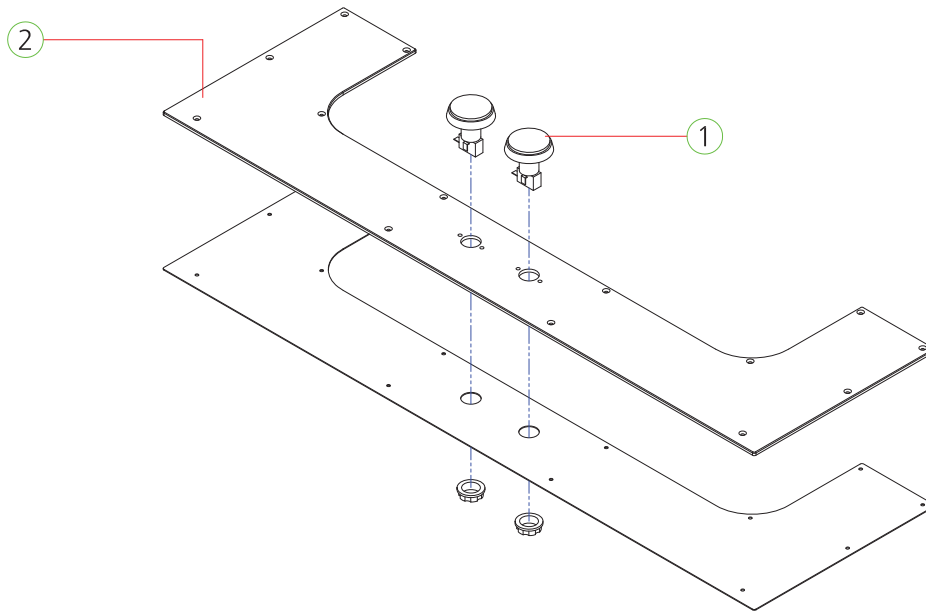

NO.	PART NAME	SPEC.	QUANTITY	CODE NO.
1	BUTTON SWITCH	AMIPB-60HR-W12D	2	MZZZ0BUT054
2	FRONT CASE BUTTON COVER ACRYL	ACRYL-3T	1	MTT00ACR014

7-7. COIN BOX PART

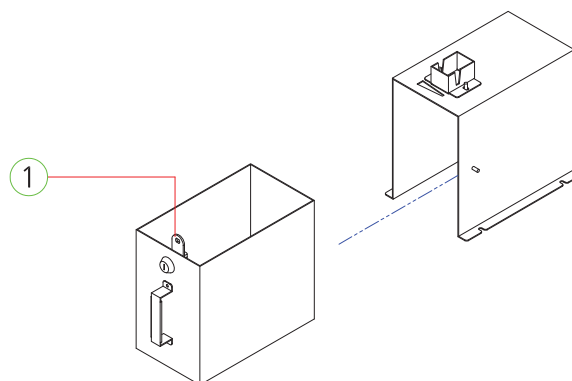

NO.	PART NAME	SPEC.	QUANTITY	CODE NO.
1	KEY ASS'Y	6001	1	-

7-8. SPEAKER PART

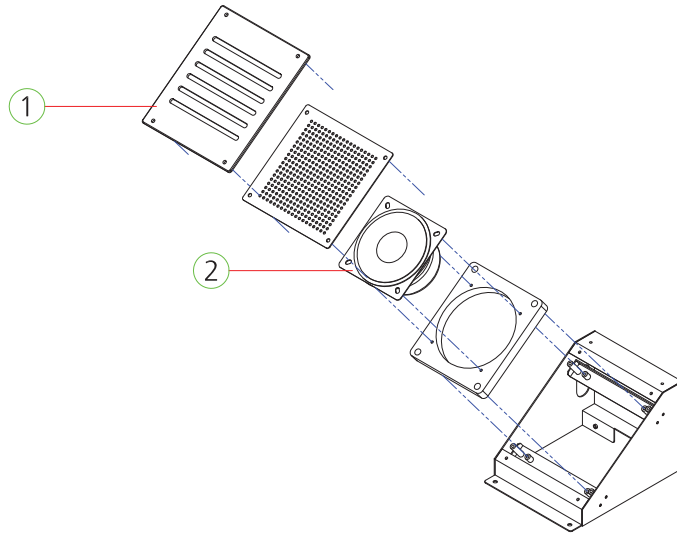

NO.	PART NAME	SPEC.	QUANTITY	CODE NO.
1	SPEAKER COVER ACRYL	ACRYL-3.0t	1	MTTO0ACR017
2	SPEAKER	MID4.5"+TW1/2" 8Ω	1	MZZZ0SPE021

7-9. BALL BLOCK PART

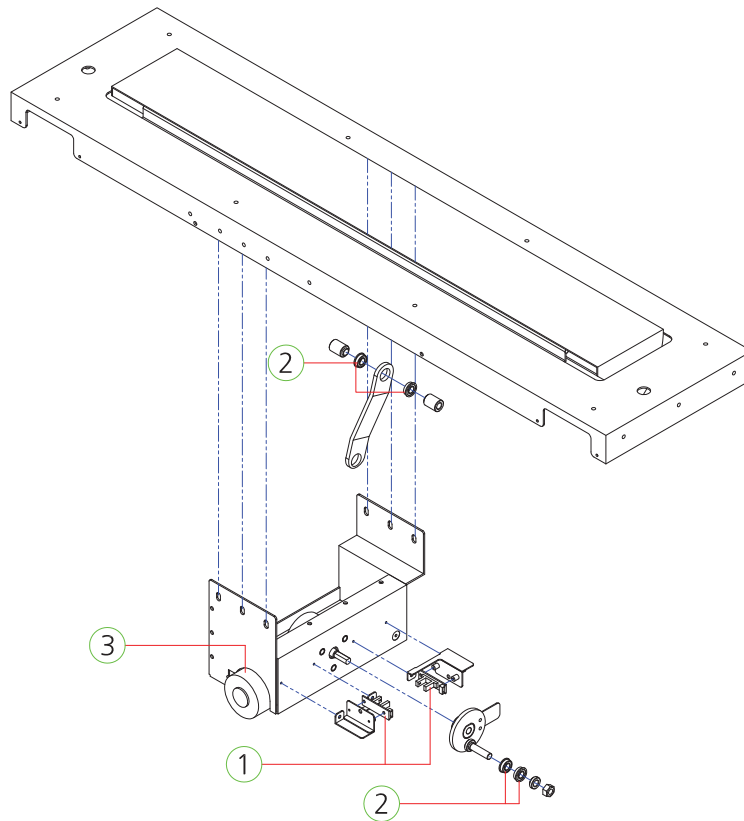

NO.	PART NAME	SPEC.	QUANTITY	CODE NO.
1	PHOTO INT-1 PCB ASS'Y	ANGLE TYPE	2	AZZZ0PCB103
2	BEARING	F688ZZ	4	MZZZ0BEA076
3	MOTOR	HM37-1232A-M005 (12V, 32RPM)Z	1	MZZZ0MOT164

7-10. MAIN BOARD PART

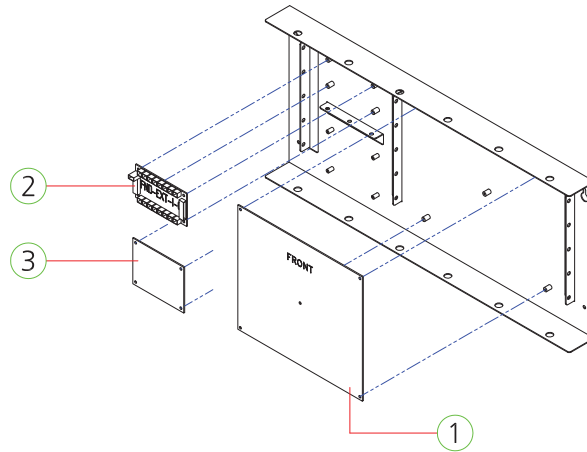

NO.	PART NAME	SPEC.	QUANTITY	CODE NO.
1	MAIN PCB ASS'Y	WITH CPU, SOUND	1	ATTO0ASS001
2	TST FND EXT IO PCB ASS'Y	90*50 16BIT EXT	1	ATTO0PCB002
3	L6205 2CH PCB ASS'Y	DC MOTOR DRIVER	1	AZZZ0PCB226

7-11. POWER SMPS PART

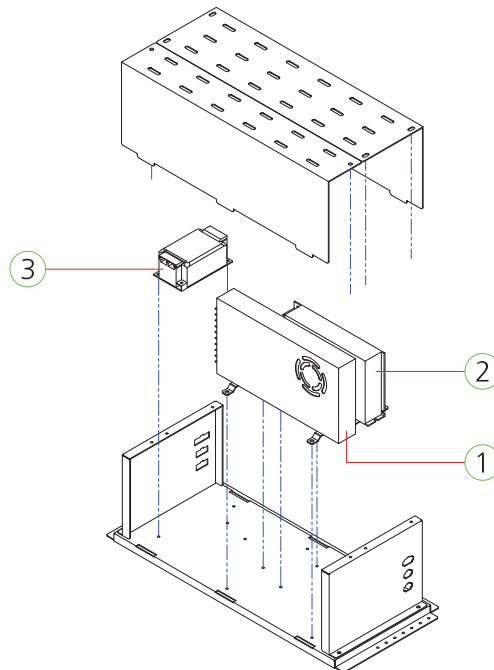

NO.	PART NAME	SPEC.	QUANTITY	CODE NO.
1	POWER SMPS	MW-RSP-320-12V	1	MELE0SMP109
2	POWER SMPS	MW-LRS-150F-5	1	MELE0SMP096
3	NOISE FILTER	RNS-2010	1	MELE0NOI009

7-12. CONTROL PANEL PART

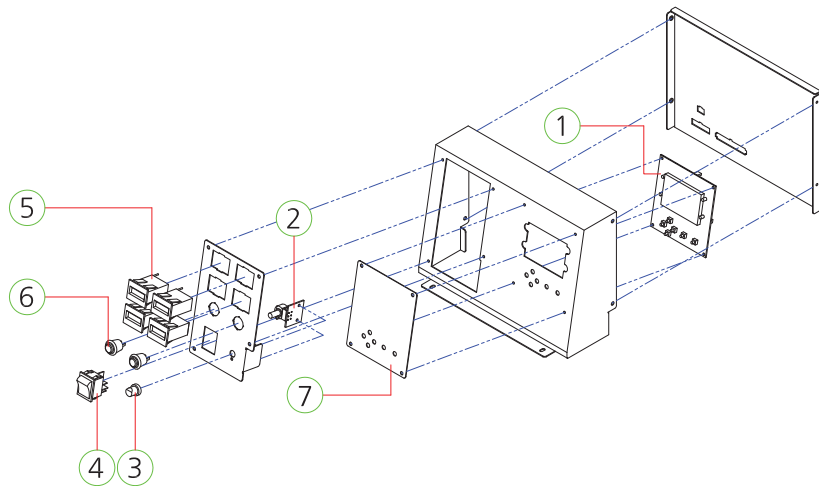

NO.	PART NAME	SPEC.	QUANTITY	CODE NO.
1	SETUP LCD PCB ASS'Y	-	1	AZZZ0PCB113
2	VOLUME PCB ASS'Y	1 VOLUME	1	AHM20PCB016
3	VOLUME KNOB	CAP BLUE	1	MELE0VOL007
4	ROCKER SWITCH	R595KDF	1	MELE0SWI021
5	COUNTER	OA127CL W/2P CONNECTOR_20CM WIRE	4	MZZZ0COU002
6	PUSH BUTTON SWITCH	DS-412R ROHS	2	MELE0PUS006
7	CONTROL PANEL COVER ACRYL	PET-1.0t	1	MTTO0ACR013

7-13. FRONT CASE DOOR PART

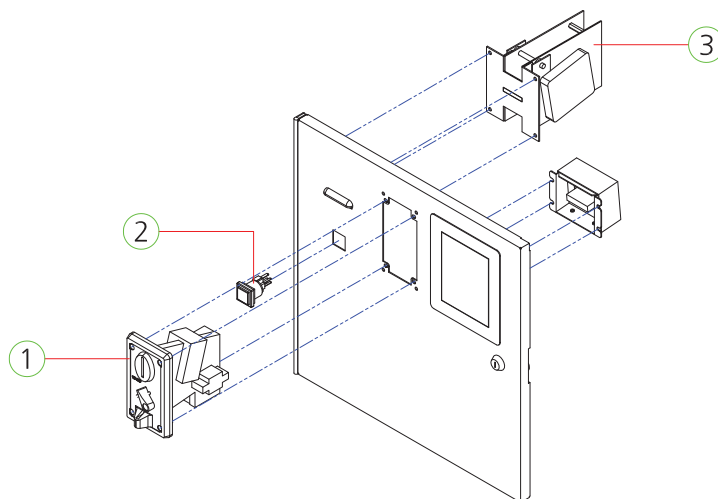

NO.	PART NAME	SPEC.	QUANTITY	CODE NO.
1	[OPTION] COIN SELECTOR	TW-389	1	MZZZ0COS052
2	TICKET BUTTON SWITCH	AM1PB-26SH R12D	1	MMUM0BUT002
3	[OPTION] TICKET DISPENSOR	CLE CL-002Q_ 270 HIGH SPEED	1	MZZZ0TID010

8. SOLUTION

* ERROR CODES

CODE	ERROR	NOTE
Er-02	SYSTEM	SETUP SAVE DATA PROBLEM
Er-03		GAME SAVE DATA PROBLEM
Er-04		SOUND FLASH AND DATA PROBLEM
Er-11	COIN MACHINE	PLAYER COIN SENSOR SIGNAL STILL PRESENT
Er-12	BILL ACCEPTOR	PLAYER BILL SENSOR SIGNAL STILL PRESENT
Er-21	BALL BRAKE	BALL BRAKE OPEN SENSOR NO SIGNAL
Er-22		BALL BRAKE CLOSE SENSOR NO SIGNAL
Er-31	CHECKER [7 8 9] [4 5 6] [1 2 3] CORRESPONDING LOCATION LED BLINKS	SENSOR 1 SIGNAL STILL ON
Er-32		SENSOR 2 SIGNAL STILL ON
Er-33		SENSOR 3 SIGNAL STILL ON
Er-34		SENSOR 4 SIGNAL STILL ON
Er-35		SENSOR 5 SIGNAL STILL ON
Er-36		SENSOR 6 SIGNAL STILL ON
Er-37		SENSOR 7 SIGNAL STILL ON
Er-38		SENSOR 8 SIGNAL STILL ON
Er-39		SENSOR 9 SIGNAL STILL ON
HEP (DISPLAY AT TICKET)	TICKET ERROR	NO TICKET

※ Reset button after taking actions

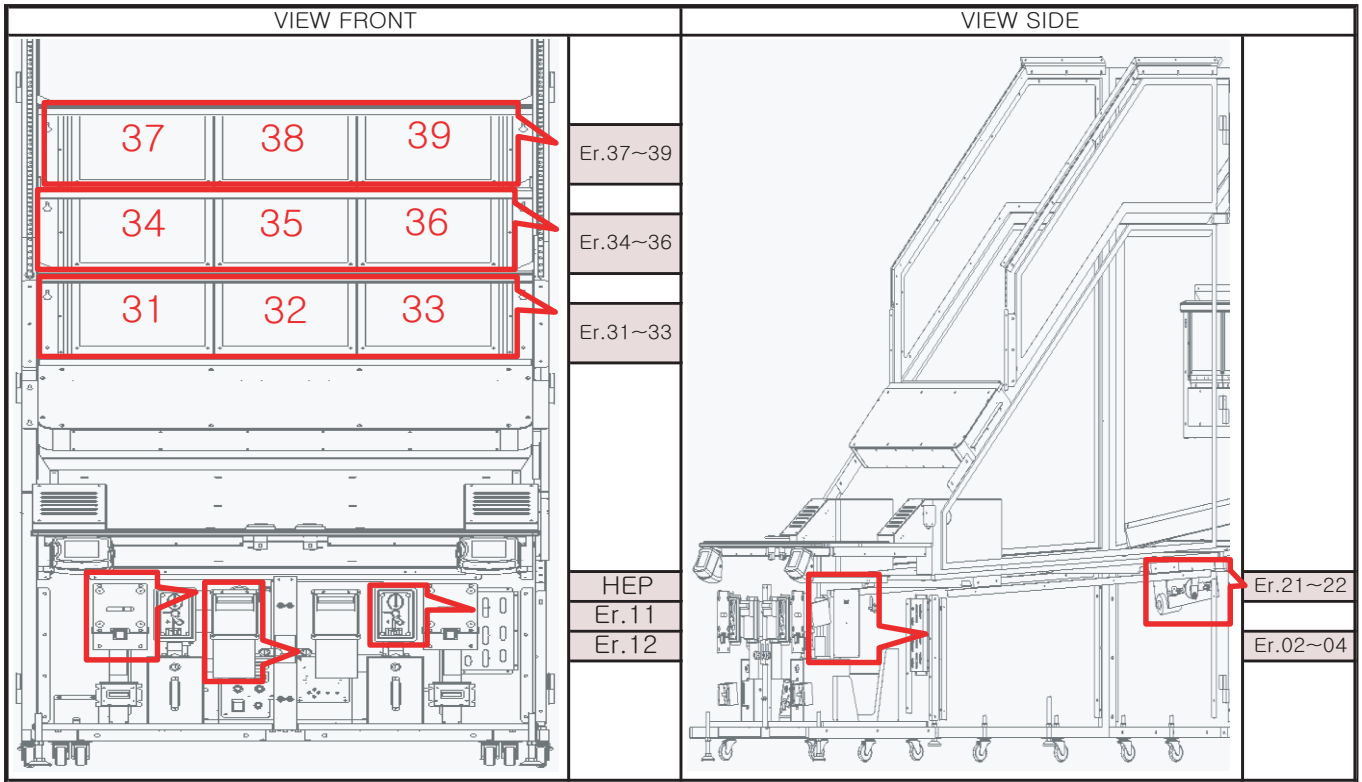

9. PCB CONNECTOR LOCATION

* PIN INFORMATION

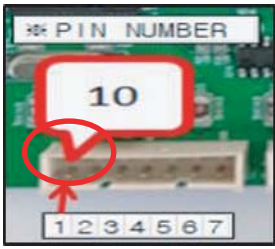
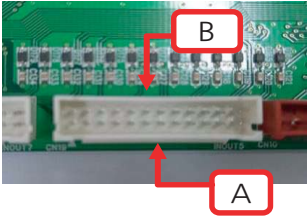
1	2	pin description
		<p>1. The arrow point means the contact pin number</p> <p>2. direction of Hirose connector</p>

9-1. MAIN PCB ASS'Y

no	FUNCTION	LOCATIO	PIN
1	MAIN PCB POWER 5V,12V	CN1	6
2	SPEAKER	J6	4
3	TICKET & EMPTY BUTTON	CN10	12
4	3rd TARGET Left/Center LED	CN19	24
5	PLAY BUTTON & MOTOR PCB	CN21	28
6	1st TARGET Left/Center LED	CN13	34
7	3rd TARGET Right LED TARGET SENSOR, MOTOR SENSOR	CN20	40
8	2nd TARGET Center/Right LED	CN18	32
9	1st TARGET Right LED, 2nd TARGET Left LED	CN17	30
A	1st FND EXT IO PCB, BILLBOARD FND	CN12	40
B	BILL ACCEPTOR	J2	10
C	COIN SELECTOR	J1	8
D	SETUP & COUNTER & VOLUME	CN9	26

9-2. 1ST FND EXT IO PCB (MAIN PCB Left)

no	FUNCTION	LOCATIO	PIN
1	FRONT TABLE, BALL READY TABLE RGB LED	J1	12
2	2nd FND EXT IO PCB INPUT	J19	10
3	DC MOTOR DRIVER PCB POWER	J22	2
4	2P SIDE TURN RGB LED	J4	7
5	1P SIDE TURN RGB LED, BILLBOARD LED	J3	11
6	MAIN PCB	J18	9
7	SMPS 12V	J17	2

9-3. 2ND FND EXT IO PCB (TURN LED ASS'Y)

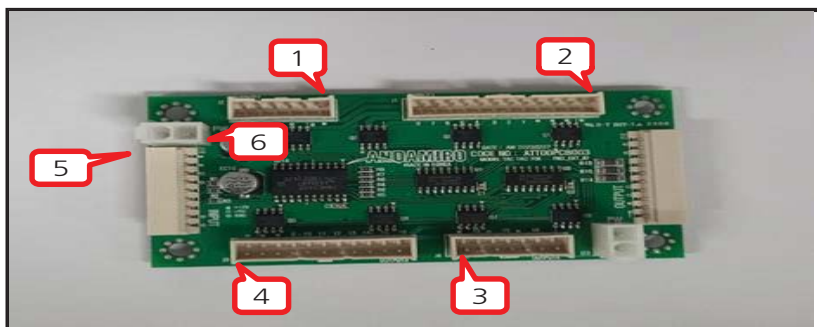

n o	FUNCTION	LOC ATIO	PIN
1	1P FRONT DECO ACRYL RGB LED	J2	6
2	RED PLAYER, DRAW, BLUE PLAYER LED	J1	12
3	TURN LED ASS'Y RGB LED	J4	7
4	2P FRONT DECO ACRYL RGB LED, REAR DECO ACRYL LED	J3	11
5	1st FND EXT IO PCB	J18	9
6	SMPS 12V	J17	2

9-4. L6205 2CH PCB ASS'Y

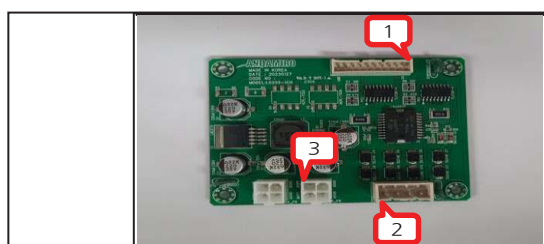

n o	FUNCTION	LOC ATIO	PIN
1	MAIN PCB	CON5	10
2	MOTOR	CON3	4
3	1st FND EXT IO PCB POWER	CON2	4

9-5. POHTO INT-1 PCB ASS'Y



n o	FUNCTION	PIN No
1	POWER 5V	1
2	ENABLE VOLTAGE	2
3	SENSOR OUT VOLTAGE	3
4	GND	4

9-6. BALL SENSOR PCB ASS'Y

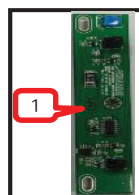

n o	FUNCTION	PIN No
1	POWER 5V	1
2	ENABLE VOLTAGE	2
3	SENSOR OUT VOLTAGE	3
4	GND	4

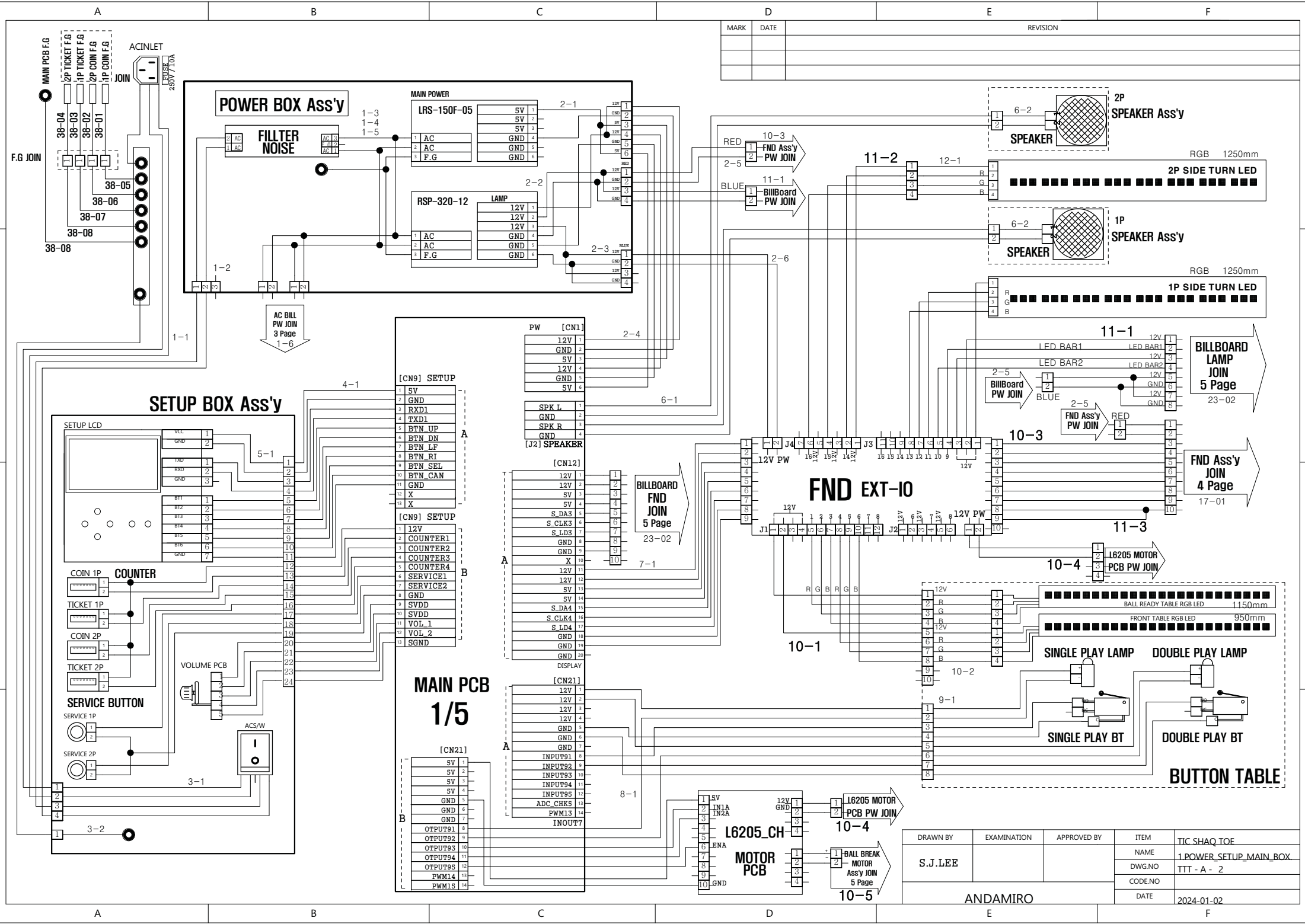

MARK	DATE	REVISION

DRAWN BY S.J.LEE	EXAMINATION	APPROVED BY	ITEM	TIC SHAQ IOE
			NAME	1.POWER_SETUP_MAIN_BOX
			DWG.NO	TTT - A - 2
			CODE.NO	
ANDAMIRO			DATE	2024-01-02

FRONT DOOR

MARK	DATE	REVISION

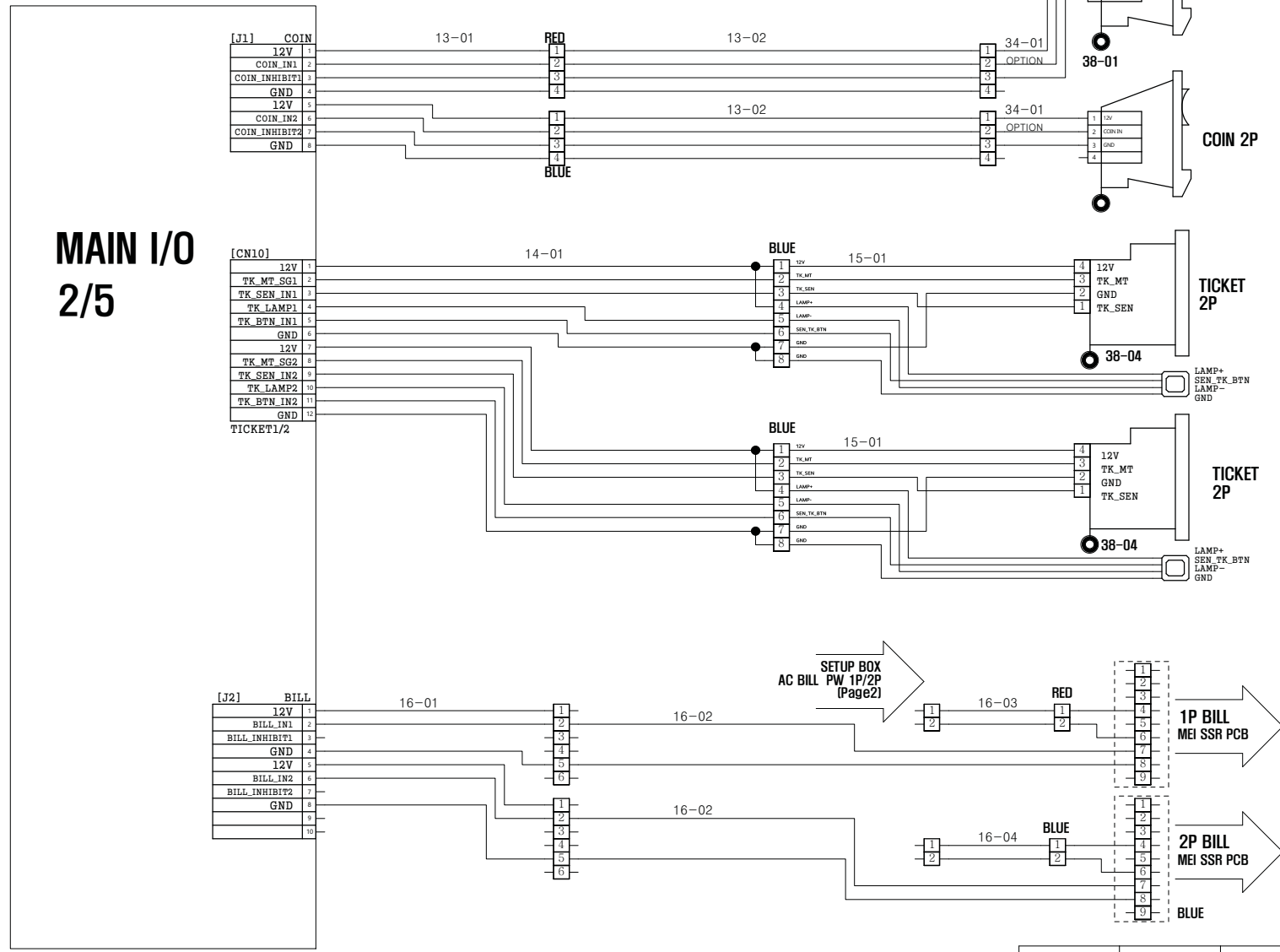

**MAIN I/O
2/5**

[J1] COIN	
12V	1
COIN_IN1	2
COIN_INHIBIT1	3
GND	4
12V	5
COIN_IN2	6
COIN_INHIBIT2	7
GND	8

[CN10]	
12V	1
TK_MT_SG1	2
TK_SEN_IN1	3
TK_LAMP1	4
TK_BTN_IN1	5
GND	6
12V	7
TK_MT_SG2	8
TK_SEN_IN2	9
TK_LAMP2	10
TK_BTN_IN2	11
GND	12
TICKET1/2	

[J2] BILL	
12V	1
BILL_IN1	2
BILL_INHIBIT1	3
GND	4
12V	5
BILL_IN2	6
BILL_INHIBIT2	7
GND	8
	9
	10

DRAWN BY	EXAMINATION	APPROVED BY	ITEM	TIC SHAQ TOE	
S.J.LEE			NAME	2.FRONT_DOOR	
				DWG.NO	TTT - A - 3
				CODE.NO	
				DATE	2024-01-02
ANDAMIRO					

MARK	DATE	REVISION

FND Ass'y
JOIN
XXX Page

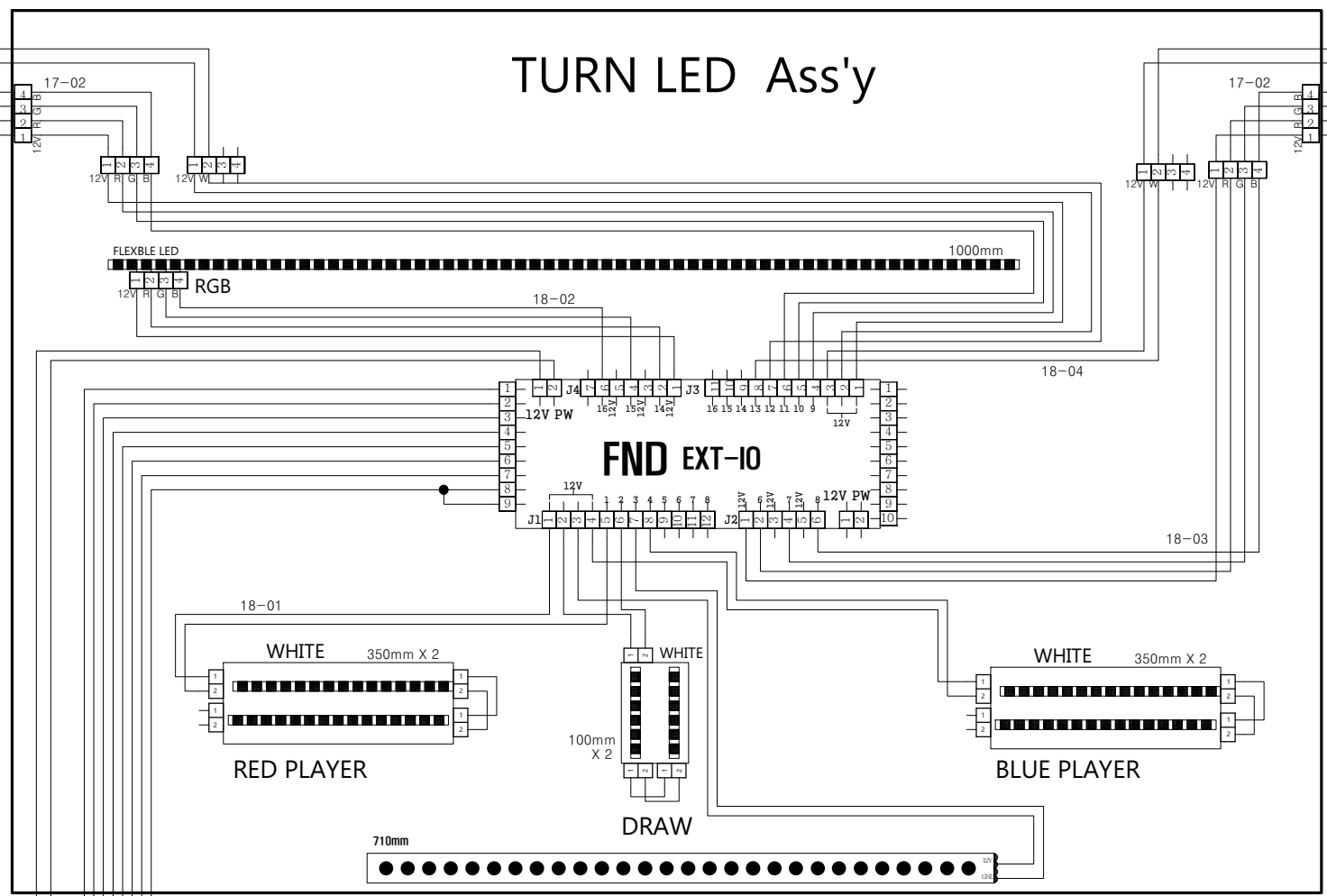

FND Ass'y
JOIN
2 Page

DRAWN BY	EXAMINATION	APPROVED BY	ITEM	TIC SHAQ TOE
S.J.LEE			NAME	3.SCORE_FND_ASSY
			DWG.NO	TTT - A - 4
			CODE.NO	
ANDAMIRO			DATE	2024-01-02

REVISION RECORD			
LN	DESCRIPTION	APPROVED	DATE

FRONT / REAR JOIN

MAIN I/O
3/5

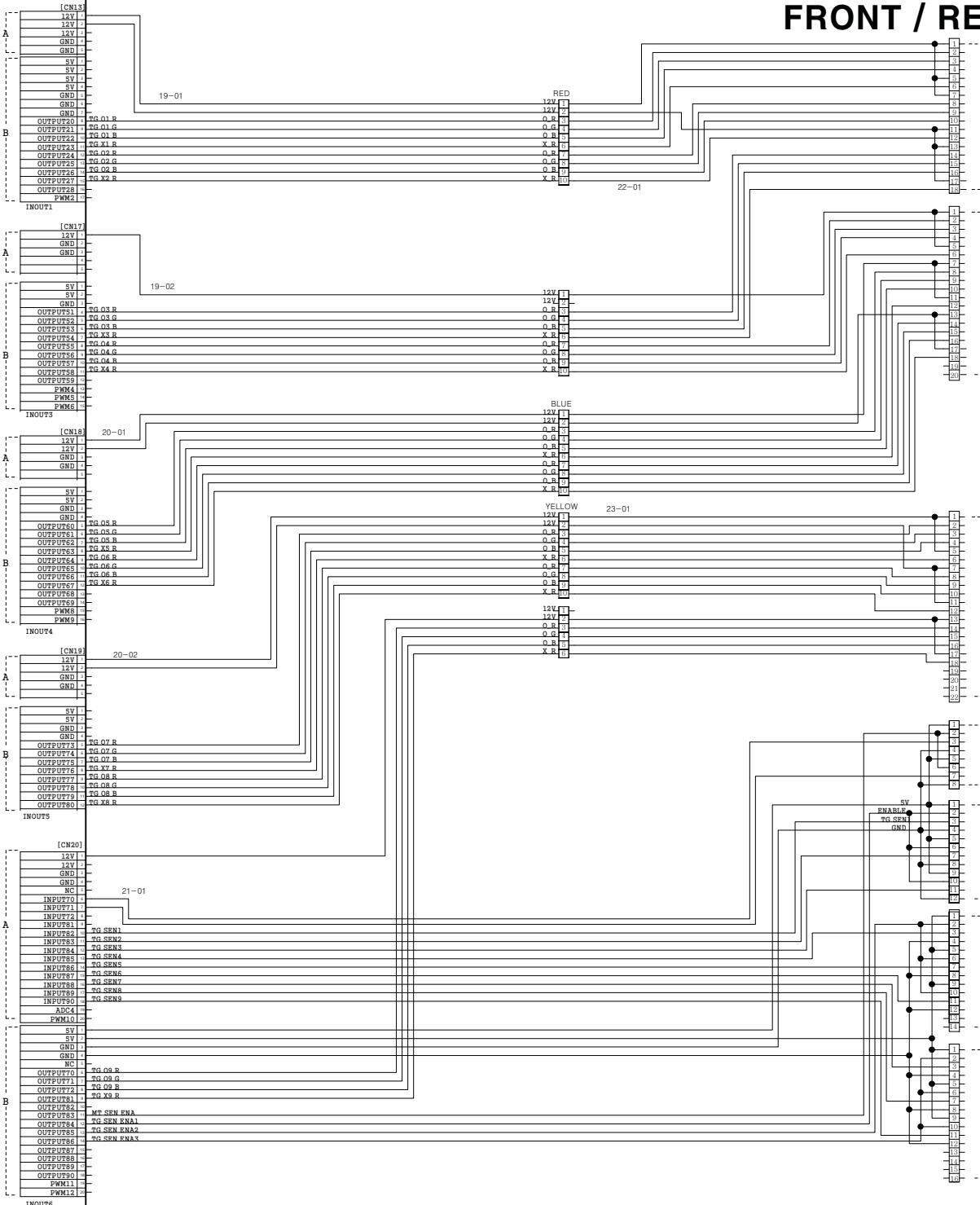

Rear Target
1st Floor
LED JOIN
7 Page
28-02

Rear Target
2nd Floor
LED JOIN
7 Page
29-02

Rear Target
3rd Floor
LED JOIN
7 Page
30-02

Rear MOTOR
SENSOR JOIN
7 Page
32-01

Rear Target
1st Floor
SENSOR JOIN
7 Page
28-01

Rear Target
2nd Floor
SENSOR JOIN
7 Page
29-01

Rear Target
3rd Floor
SENSOR JOIN
7 Page
30-01

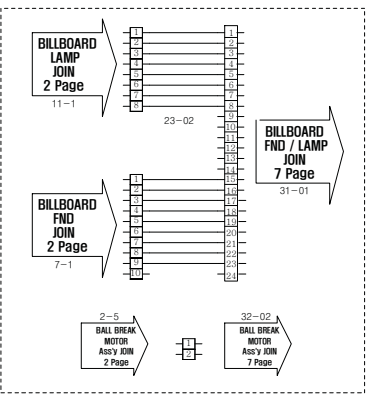

DRAWN		DATE		DRAWING NO.		REV.	
Lee Seung Jae		2024-01-02		ANDAMIRO TIC SHAQ TOE 4.MAIN_PCB		TTT - A - 5	
CHECKED		DATE		SCALE		SHEET: 5 OF 9	
QUALITY CONTROL		DATE		A1		TTT - A - 5	
RELEASD		DATE		SCALE		SHEET: 5 OF 9	

REAR PART

MARK	DATE	REVISION

28-01 1st Floor
29-01 2nd Floor
30-01 3rd Floor

Rear Target
SENSOR JOIN
7 Page

24-01 1st Floor
25-01 2nd Floor
26-01 3rd Floor

Target Ass'y X 3

28-02 1st Floor
29-02 2nd Floor
30-02 3rd Floor

Rear Target
LED JOIN
7 Page

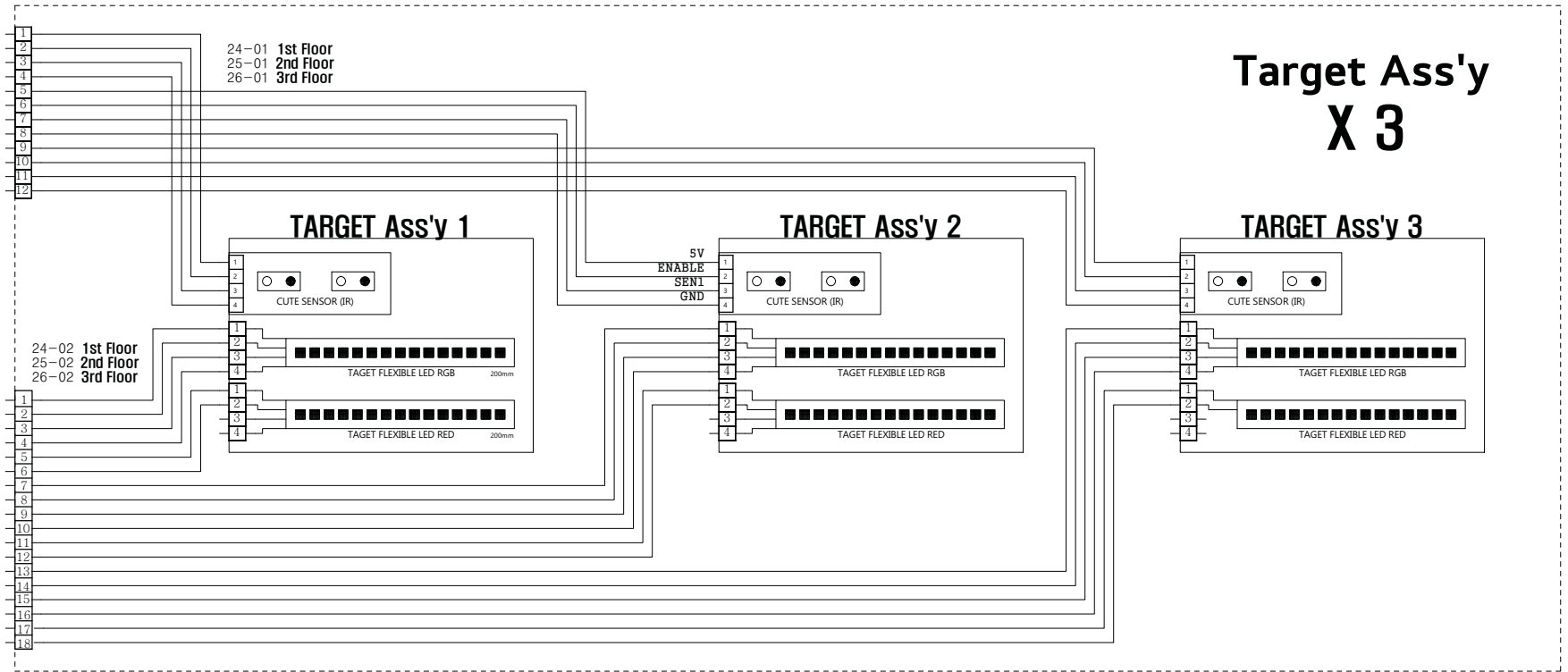

DRAWN BY	EXAMINATION	APPROVED BY	ITEM NAME	TIC SHAQ TOE
S.J.LEE			5.TAGET_ASSY	
			DWG.NO	TTT - A - 6
			CODE.NO	
			DATE	2024-01-02
ANDAMIRO				

FRONT / REAR JOIN WIRE

MARK	DATE	REVISION

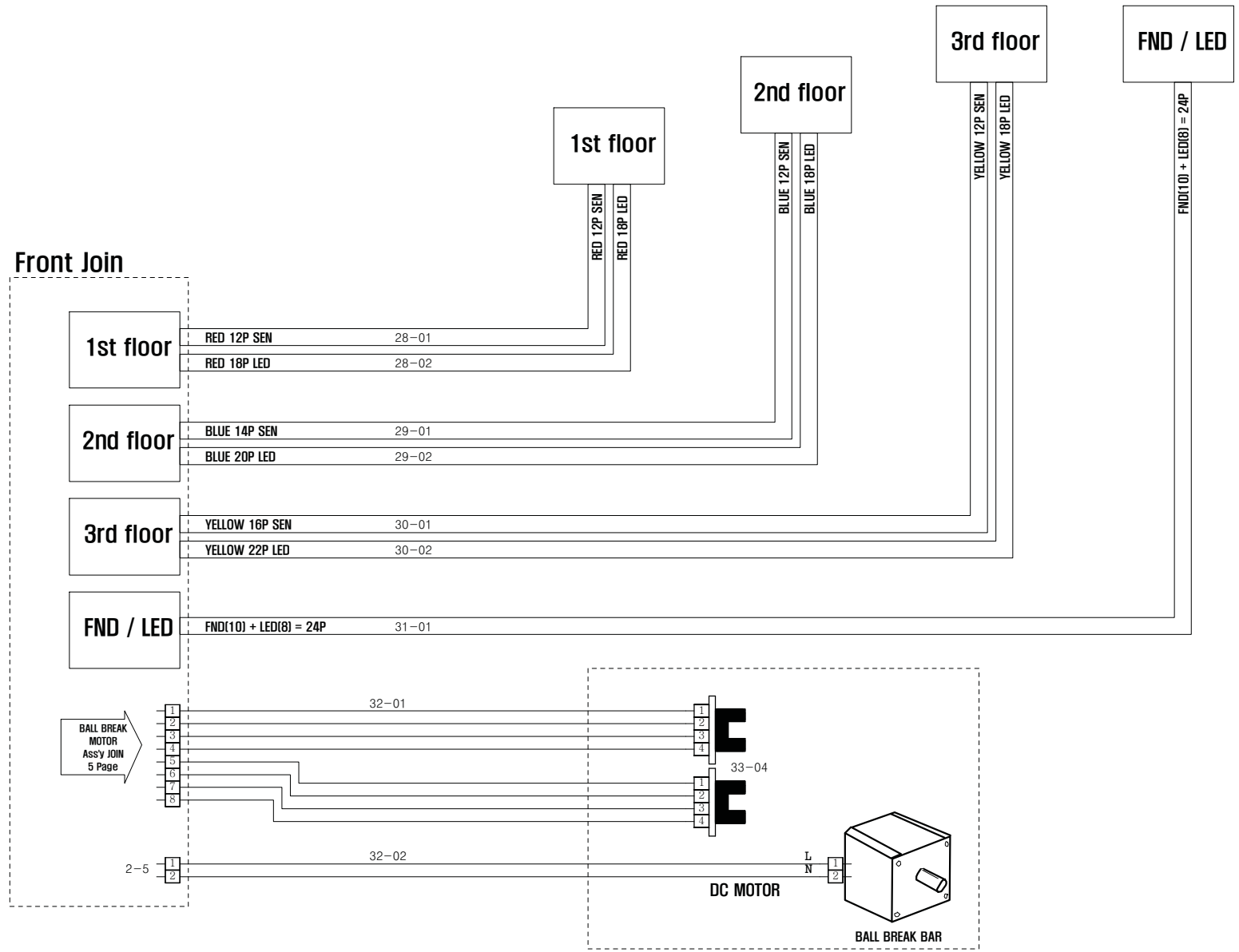

DRAWN BY	EXAMINATION	APPROVED BY	ITEM NAME	TIC SHAQ TOE
S.J.LEE			6.FRONT_REAR_JOIN_WIRE	
			DWG.NO	TTT - A - 7
			CODE.NO	
			DATE	2024-01-02

ANDAMIRO

MARK	DATE	REVISION

REAR PART

BILLBOARD Ass'y

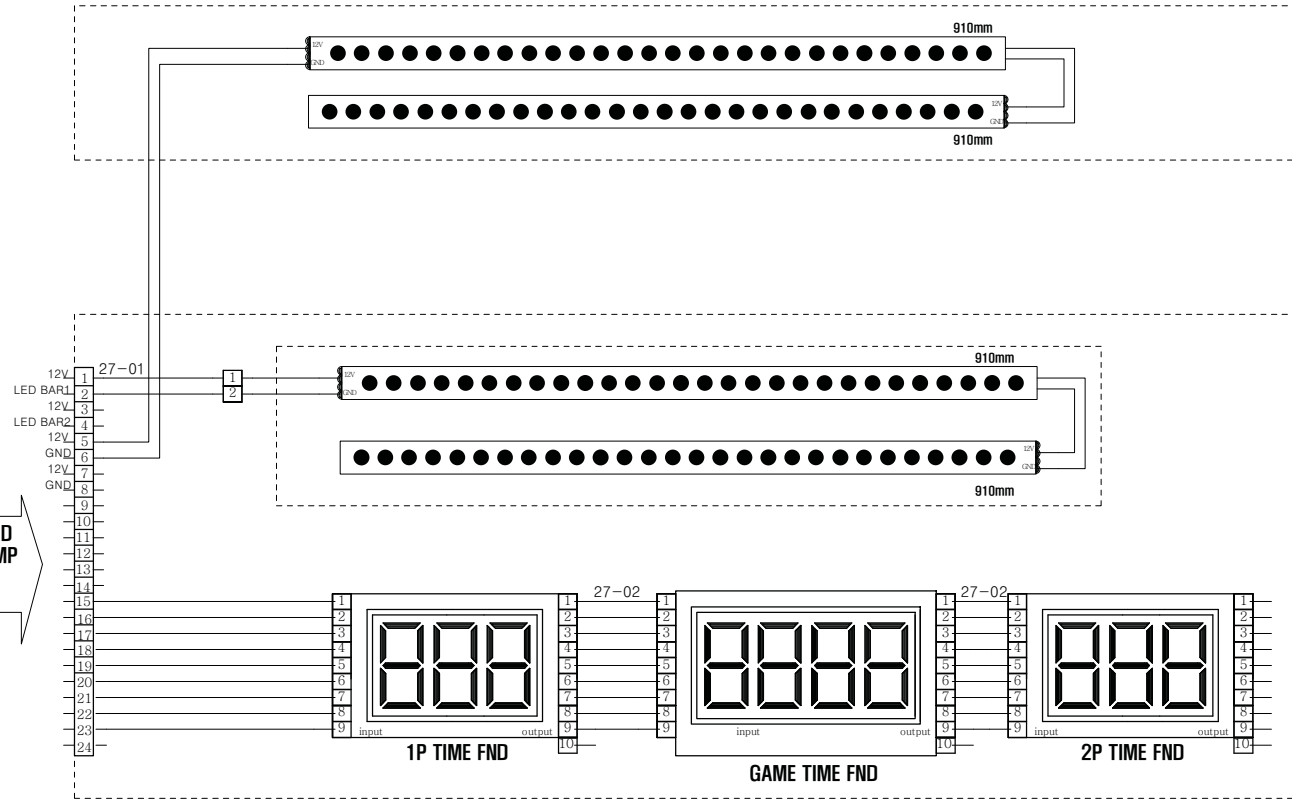

BILLBOARD FND / LAMP JOIN
7 Page
31-01

DRAWN BY	EXAMINATION	APPROVED BY	ITEM	TIC SHAQ TOE
S.J.LEE			NAME	7.BILLBOARD
			DWG.NO	TTT - A - 8
			CODE.NO	
			DATE	2024-01-02
ANDAMIRO				

LED BAR3
LED BAR4

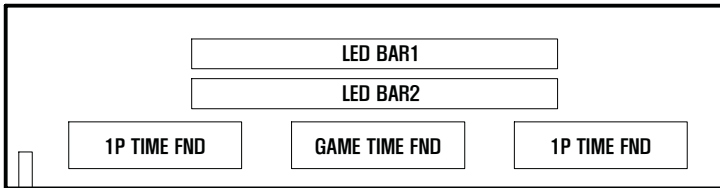

5 PAGE

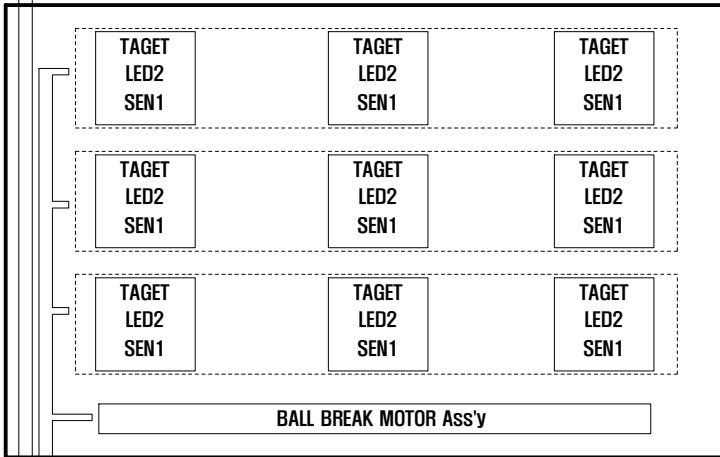

6 PAGE

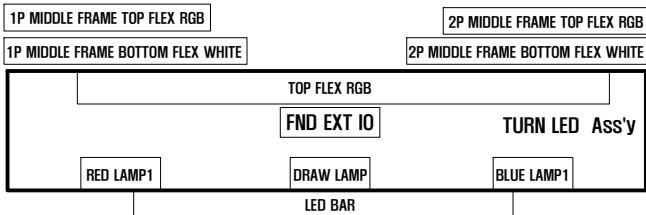

3 PAGE

4 PAGE

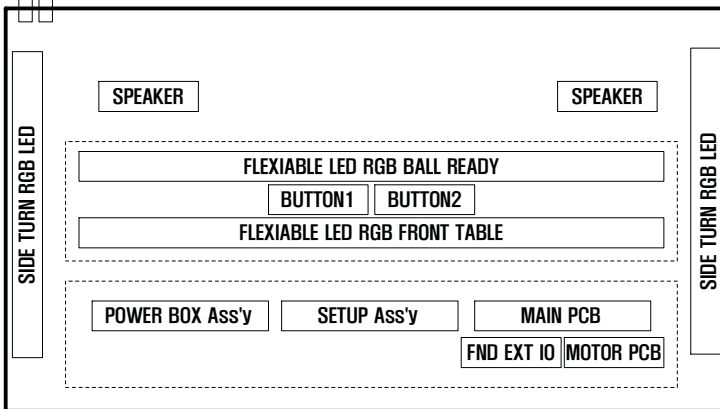

1 PAGE

2 PAGE



11. WARRANTY ITEM

- BILLBOARD PART

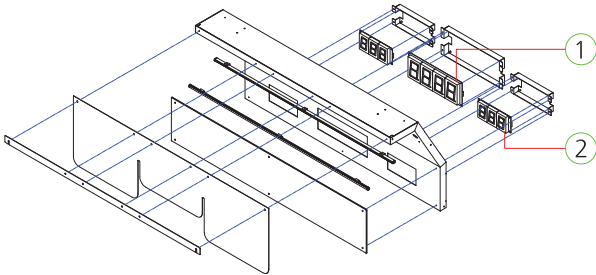

- TARGET TOTAL PART-A PART
[A, B, C PART Identical parts applied]

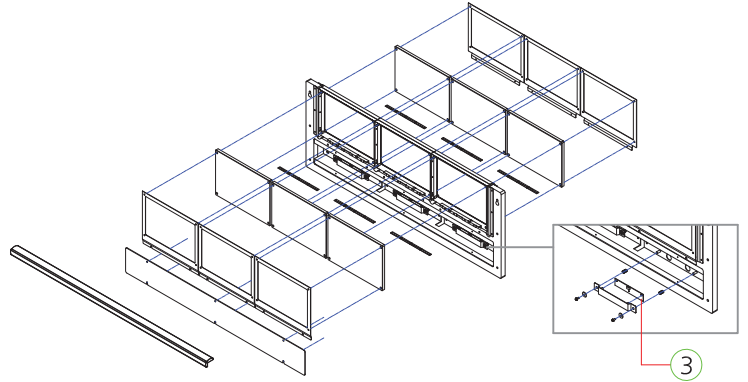

- PLAYER TURN LED PART

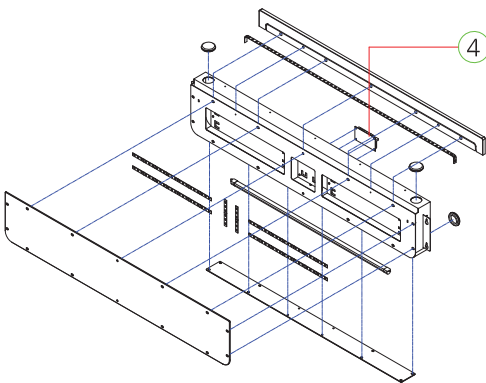

- BALL BLOCK PART

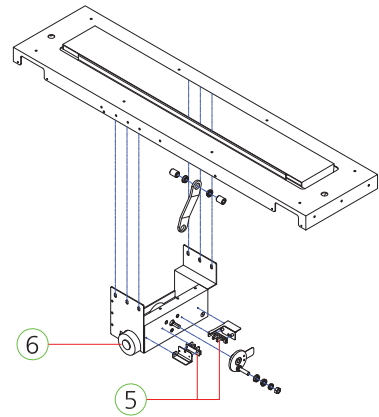

- MAIN BOARD PART

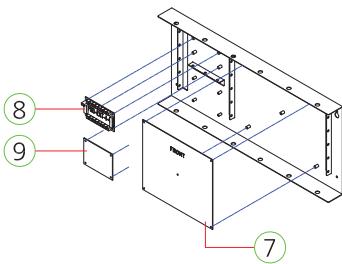

- POWER SMPS PART

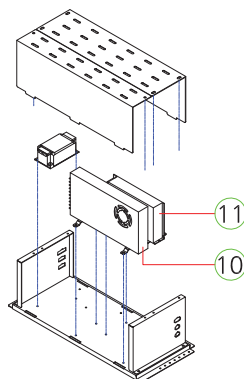

- CONTROL PANEL PART

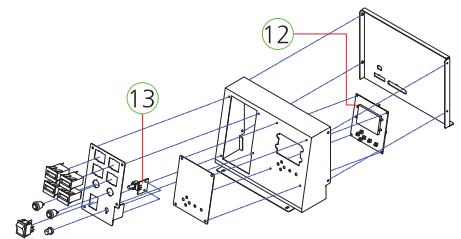

NO.	PART NAME	SPEC.	QTY	CODE NO.	WARRANTY	
					6 Month	One Year
①	FND PCB ASS'Y	6390-4(STRAIGHT)	1	AFND0PCB011		○
②	FND PCB ASS'Y	4870-3(STRAIGHT)	2	AFND0PCB027		○
③	BALL SENSOR PCB ASS'Y	38Khz 2Point	3	ATTO0PCB001		○
④	TST FND EXT IO PCB ASS'Y	90*50 16BIT EXT	1	ATTO0PCB002		○
⑤	PHOTO INT-1 PCB ASS'Y	ANGLE TYPE	2	AZZZ0PCB103		○
⑥	MOTOR	HM37-1232A-M005 (12V, 32RPM)Z	1	MZZZ0MOT164	○	
⑦	MAIN PCB ASS'Y	WITH CPU, SOUND	1	ATTO0ASS001		○
⑧	TST FND EXT IO PCB ASS'Y	90*50 16BIT EXT	1	ATTO0PCB002		○
⑨	L6205 2CH PCB ASS'Y	DC MOTOR DRIVER	1	AZZZ0PCB226		○
⑩	POWER SMPS	MW-RSP-320-12V	1	MELE0SMP109		○
⑪	POWER SMPS	MW-LRS-150F-5	1	MELE0SMP096		○
⑫	SETUP LCD PCB ASS'Y	-	1	AZZZ0PCB113		○
⑬	VOLUME PCB ASS'Y	1 VOLUME	1	AHM20PCB016		○

12. TROUBLE SHOOTING

12-1. RIGION ERROR (Er01)

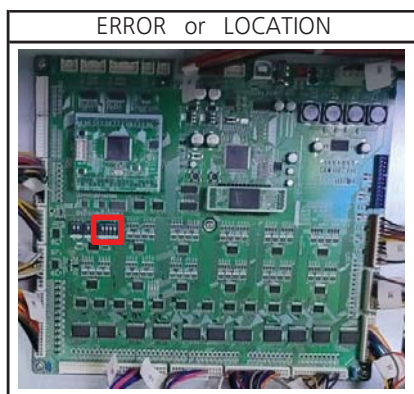

► SOLUTION

1. CHECK :
 - 1) Check the location of MAIN PCB DIP SW 6
 - 2) Check after executing FACTORY SETTING
 - 3) MAIN PCB Replacement

PART NAME	CODE	PART NAME	CODE
MAIN PCB ASS'Y	AZZZ0ASS222	CPU PCB ASS'Y	ATTO0PCB003

12-2. SYSTEM ERROR (Er02, Er03, Er04)

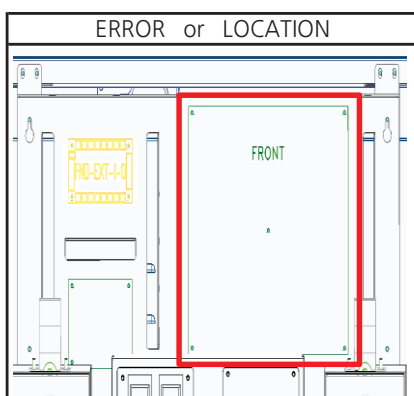

► SOLUTION

1. CHECK :
 - 1) Check after turning the power on and off
 - 2) Confirm after FACTORY SETTING
 - 3) MAIN PCB Replacement

PART NAME	CODE	PART NAME	CODE
MAIN PCB ASS'Y	AZZZ0ASS082	CPU PCB ASS'Y	ATTO0PCB003

12-3. COIN MACHINE ERROR (Er.11)

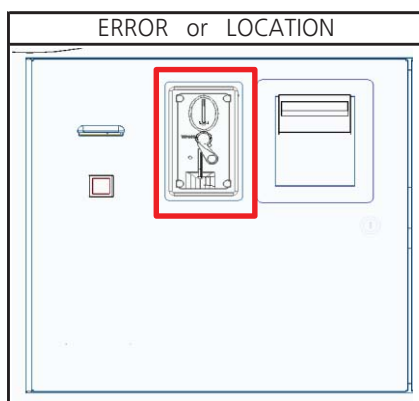

► SOLUTION

1. TEST MODE → COIN TEST
2. CHECK :
 - 1) Check if COIN JAM has occurred
 - 2) Check wiring connections
 - 3) Coin machine replacement
 - 4) MAIN PCB Replacement

PART NAME	CODE	PART NAME	CODE
[OPTION] COIN SELECTOR	MZZZ0COS052	MAIN PCB ASS'Y	ATTO0ASS001

12-4. BILL ACCEPTOR ERROR (Er.12)

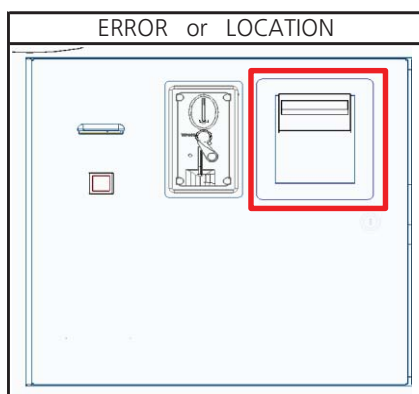





► SOLUTION

1. TEST MODE → BILL TEST
2. CHECK :
 - 1) Check whether there is JAM on BILL
 - 2) Check wiring connections
 - 3) BILL machine replacement
 - 4) MAIN PCB Replacement

PART NAME	CODE	PART NAME	CODE
MAIN PCB ASS'Y	ATTO0ASS001		

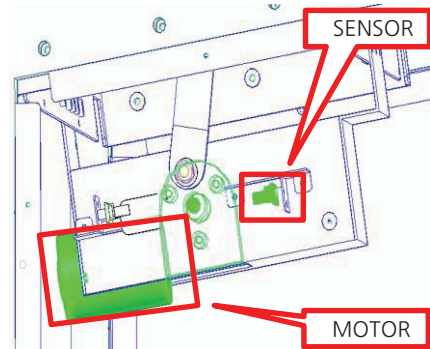
12-5. BALL BREAK OPEN MOTOR & SENSOR ERROR (Er.21)

*Normal operation only up to 5 seconds upon execution

ERROR or LOCATION	P1	P2																													
	 	 <table border="1" style="margin-left: 20px;"> <tr><td>1</td><td>Over 11V</td></tr> <tr><td>2</td><td>GND</td></tr> </table>  <table border="1" style="margin-left: 20px;"> <tr><td>5</td><td>1</td><td>1</td><td>Over 4.5V</td><td></td></tr> <tr><td>6</td><td>2</td><td>2</td><td>Below 1.0V</td><td></td></tr> <tr><td>7</td><td>3</td><td>3</td><td>Over 4.5V</td><td>undetected</td></tr> <tr><td>8</td><td>4</td><td>3</td><td>Below 0.1V</td><td>detect</td></tr> <tr><td></td><td></td><td>4</td><td>GND</td><td></td></tr> </table>	1	Over 11V	2	GND	5	1	1	Over 4.5V		6	2	2	Below 1.0V		7	3	3	Over 4.5V	undetected	8	4	3	Below 0.1V	detect			4	GND	
1	Over 11V																														
2	GND																														
5	1	1	Over 4.5V																												
6	2	2	Below 1.0V																												
7	3	3	Over 4.5V	undetected																											
8	4	3	Below 0.1V	detect																											
		4	GND																												

► SOLUTION



1. TEST MODE → BALL BREAK
 - BLUE TURN FND : OPEN sensor status display in the first digit (Recognize : "1", unrecognized : "0")
2. CHECK :
 - 1) Check motor and bracket assembly condition (P1)
 - 2) Check sensor assembly status (P1)
 - 3) Check wiring connection (P1)

- 4) Check motor voltage (P2)
- 5) Motor replacement
- 6) Check sensor voltage (P2)
- 7) Sensor PCB replacement
- 8) Main PCB replacement

PART NAME	CODE	PART NAME	CODE
MOTOR	MZZZ0MOT164	PHOTO INT-1 PCB ASS'Y	AZZZ0PCB103
MAIN PCB ASS'Y	ATTO0ASS001		

12-6. BALL BREAK CLOSE MOTOR & SENSOR ERROR (Er.22)

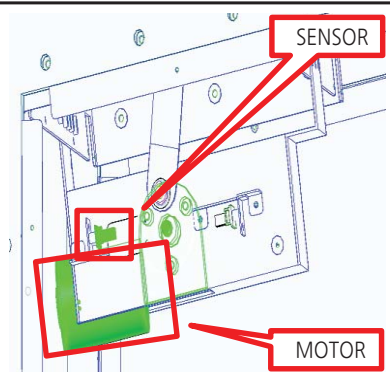
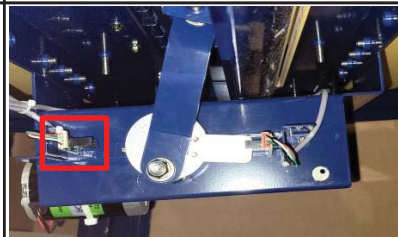
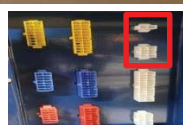
*Normal operation only up to 5 seconds upon execution

ERROR or LOCATION	P1	P2																													
	 	 <table border="1" style="margin-left: 20px;"> <tr><td>1</td><td>Over 11V</td></tr> <tr><td>2</td><td>GND</td></tr> </table>  <table border="1" style="margin-left: 20px;"> <tr><td>5</td><td>1</td><td>5</td><td>Over 4.5V</td><td></td></tr> <tr><td>6</td><td>2</td><td>6</td><td>Below 1.0V</td><td></td></tr> <tr><td>7</td><td>3</td><td>7</td><td>Over 4.5V</td><td>undetected</td></tr> <tr><td>8</td><td>4</td><td>3</td><td>Below 0.1V</td><td>detect</td></tr> <tr><td></td><td></td><td>8</td><td>GND</td><td></td></tr> </table>	1	Over 11V	2	GND	5	1	5	Over 4.5V		6	2	6	Below 1.0V		7	3	7	Over 4.5V	undetected	8	4	3	Below 0.1V	detect			8	GND	
1	Over 11V																														
2	GND																														
5	1	5	Over 4.5V																												
6	2	6	Below 1.0V																												
7	3	7	Over 4.5V	undetected																											
8	4	3	Below 0.1V	detect																											
		8	GND																												

► SOLUTION

1. TEST MODE → BALL BREAK
 - BLUE TURN FND : CLOSE sensor status in the third digit (Recognize : "1", unrecognized : "0")
2. CHECK :
 - 1) Check motor and bracket assembly condition (P1)
 - 2) Check sensor assembly status (P1)
 - 3) Check wiring connection (P1)

- 4) Check motor voltage (P2)
- 5) Motor replacement
- 6) Check sensor voltage (P2)
- 7) Sensor PCB replacement
- 8) Main PCB replacement

PART NAME	CODE	PART NAME	CODE
MOTOR	MZZZ0MOT164	PHOTO INT-1 PCB ASS'Y	AZZZ0PCB103
MAIN PCB ASS'Y	ATTO0ASS001		

12-7. CHECKER "No. 1" SENSOR ERROR (Er.31)

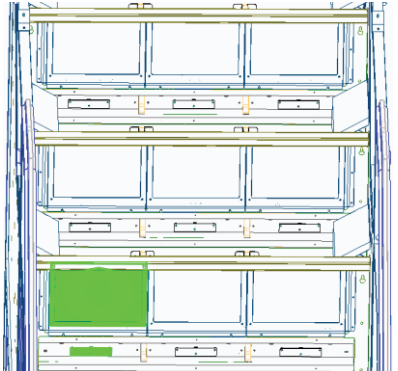
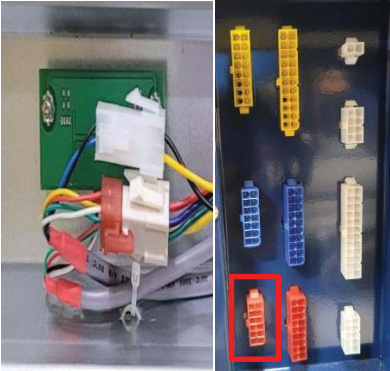
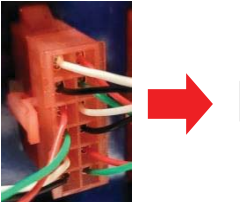
ERROR or LOCATION	P1	P2															
		 <table border="1" data-bbox="1189 168 1268 369"> <tr><td>7</td><td>1</td></tr> <tr><td>8</td><td>2</td></tr> <tr><td>9</td><td>3</td></tr> <tr><td>10</td><td>4</td></tr> <tr><td>11</td><td>5</td></tr> <tr><td>12</td><td>6</td></tr> </table>	7	1	8	2	9	3	10	4	11	5	12	6			
7	1																
8	2																
9	3																
10	4																
11	5																
12	6																
		<table border="1" data-bbox="933 380 1316 537"> <tr><td>1</td><td>Over 4.5V</td><td></td></tr> <tr><td>2</td><td>Below 1.0V</td><td></td></tr> <tr><td>3</td><td>Over 4.5V</td><td>undetected</td></tr> <tr><td></td><td>Below 0.2V</td><td>detect</td></tr> <tr><td>4</td><td>GND</td><td></td></tr> </table>	1	Over 4.5V		2	Below 1.0V		3	Over 4.5V	undetected		Below 0.2V	detect	4	GND	
1	Over 4.5V																
2	Below 1.0V																
3	Over 4.5V	undetected															
	Below 0.2V	detect															
4	GND																

► SOLUTION

1. TEST MODE → INPUT TEST

- CHECKER LED : "O" , "X" LED recognition status display
(Recognized: "O", Unrecognized: "X")
- SOUND output : "1" sound output when the sensor is recognized

2. CHECK :

- 1) Check sensor assembly (P1)
- 2) Check wiring connections (P1)
- 3) Check sensor voltage (P2)
- 4) Sensor PCB replacement
- 5) Main PCB replacement

PART NAME	CODE	PART NAME	CODE
BALL SENSOR PCB ASS'Y	ATTO0PCB001	MAIN PCB ASS'Y	ATTO0ASS001

12-8. CHECKER "No. 2" SENSOR ERROR (Er.32)

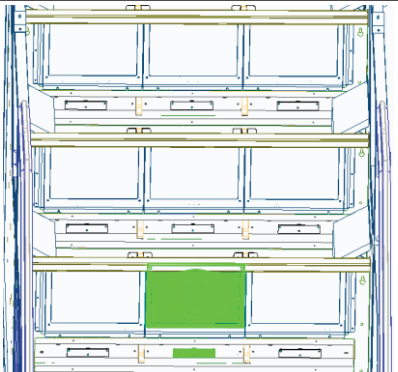
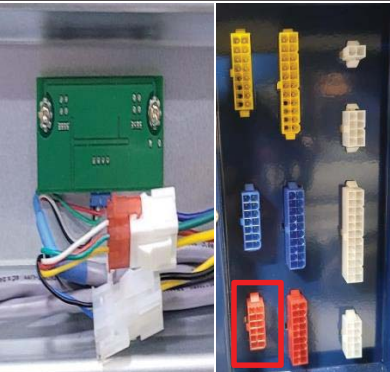
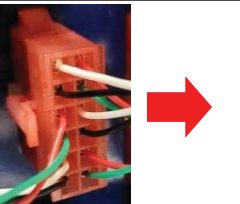
ERROR or LOCATION	P1	P2															
		 <table border="1" data-bbox="1189 1209 1268 1411"> <tr><td>7</td><td>1</td></tr> <tr><td>8</td><td>2</td></tr> <tr><td>9</td><td>3</td></tr> <tr><td>10</td><td>4</td></tr> <tr><td>11</td><td>5</td></tr> <tr><td>12</td><td>6</td></tr> </table>	7	1	8	2	9	3	10	4	11	5	12	6			
7	1																
8	2																
9	3																
10	4																
11	5																
12	6																
		<table border="1" data-bbox="933 1422 1316 1579"> <tr><td>5</td><td>Over 4.5V</td><td></td></tr> <tr><td>6</td><td>Below 1.0V</td><td></td></tr> <tr><td>7</td><td>Over 4.5V</td><td>undetected</td></tr> <tr><td></td><td>Below 0.2V</td><td>detect</td></tr> <tr><td>8</td><td>GND</td><td></td></tr> </table>	5	Over 4.5V		6	Below 1.0V		7	Over 4.5V	undetected		Below 0.2V	detect	8	GND	
5	Over 4.5V																
6	Below 1.0V																
7	Over 4.5V	undetected															
	Below 0.2V	detect															
8	GND																

► SOLUTION

1. TEST MODE → INPUT TEST



- CHECKER LED : "O" , "X" LED recognition status display
(Recognized: "O", Unrecognized: "X")
- SOUND output : "2" sound output when the sensor is recognized

2. CHECK :

- 1) Check sensor assembly (P1)
- 2) Check wiring connections (P1)
- 3) Check sensor voltage (P2)
- 4) Sensor PCB replacement
- 5) Main PCB replacement

PART NAME	CODE	PART NAME	CODE
BALL SENSOR PCB ASS'Y	ATTO0PCB001	MAIN PCB ASS'Y	ATTO0ASS001

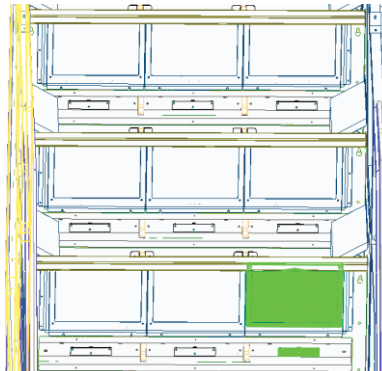
12-9. CHECKER "No. 3" SENSOR ERROR (Er.33)

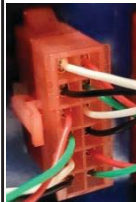
ERROR or LOCATION	P1	P2															
		 <table border="1" data-bbox="1197 168 1276 369"> <tr><td>7</td><td>1</td></tr> <tr><td>8</td><td>2</td></tr> <tr><td>9</td><td>3</td></tr> <tr><td>10</td><td>4</td></tr> <tr><td>11</td><td>5</td></tr> <tr><td>12</td><td>6</td></tr> </table>	7	1	8	2	9	3	10	4	11	5	12	6			
7	1																
8	2																
9	3																
10	4																
11	5																
12	6																
		<table border="1" data-bbox="933 380 1316 537"> <tr><td>9</td><td>Over 4.5V</td><td></td></tr> <tr><td>10</td><td>Below 1.0V</td><td></td></tr> <tr><td>11</td><td>Over 4.5V</td><td>undetected</td></tr> <tr><td></td><td>Below 0.2V</td><td>detect</td></tr> <tr><td>12</td><td>GND</td><td></td></tr> </table>	9	Over 4.5V		10	Below 1.0V		11	Over 4.5V	undetected		Below 0.2V	detect	12	GND	
9	Over 4.5V																
10	Below 1.0V																
11	Over 4.5V	undetected															
	Below 0.2V	detect															
12	GND																

► SOLUTION

1. TEST MODE → INPUT TEST

- CHECKER LED : "O" , "X" LED recognition status display
(Recognized: "O", Unrecognized: "X")
- SOUND output : "3" sound output when the sensor is recognized

2. CHECK :

- 1) Check sensor assembly (P1)
- 2) Check wiring connections (P1)
- 3) Check sensor voltage (P2)
- 4) Sensor PCB replacement
- 5) Main PCB replacement

PART NAME	CODE	PART NAME	CODE
BALL SENSOR PCB ASS'Y	ATTO0PCB001	MAIN PCB ASS'Y	ATTO0ASS001

12-10. CHECKER "No. 4" SENSOR ERROR (Er.34)

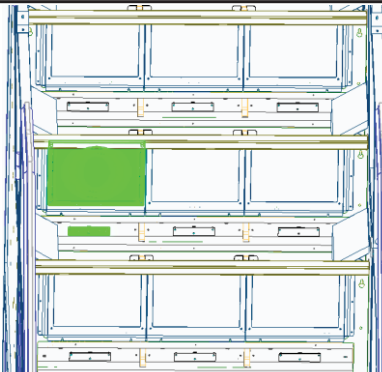
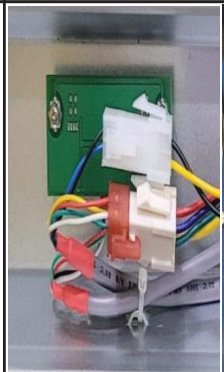
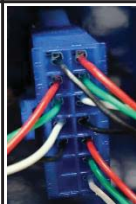
ERROR or LOCATION	P1	P2															
		 <table border="1" data-bbox="1197 1209 1276 1411"> <tr><td>8</td><td>1</td></tr> <tr><td>9</td><td>2</td></tr> <tr><td>10</td><td>3</td></tr> <tr><td>11</td><td>4</td></tr> <tr><td>12</td><td>5</td></tr> <tr><td>13</td><td>6</td></tr> <tr><td>14</td><td>7</td></tr> </table>	8	1	9	2	10	3	11	4	12	5	13	6	14	7	
8	1																
9	2																
10	3																
11	4																
12	5																
13	6																
14	7																
		<table border="1" data-bbox="933 1422 1316 1579"> <tr><td>1</td><td>Over 4.5V</td><td></td></tr> <tr><td>2</td><td>Below 1.0V</td><td></td></tr> <tr><td>3</td><td>Over 4.5V</td><td>undetected</td></tr> <tr><td></td><td>Below 0.2V</td><td>detect</td></tr> <tr><td>4</td><td>GND</td><td></td></tr> </table>	1	Over 4.5V		2	Below 1.0V		3	Over 4.5V	undetected		Below 0.2V	detect	4	GND	
1	Over 4.5V																
2	Below 1.0V																
3	Over 4.5V	undetected															
	Below 0.2V	detect															
4	GND																

► SOLUTION

1. TEST MODE → INPUT TEST

- CHECKER LED : "O" , "X" LED recognition status display
(Recognized: "O", Unrecognized: "X")
- SOUND output : "4" sound output when the sensor is recognized

2. CHECK :

- 1) Check sensor assembly (P1)
- 2) Check wiring connections (P1)
- 3) Check sensor voltage (P2)
- 4) Sensor PCB replacement
- 5) Main PCB replacement

PART NAME	CODE	PART NAME	CODE
BALL SENSOR PCB ASS'Y	ATTO0PCB001	MAIN PCB ASS'Y	ATTO0ASS001

12-11. CHECKER "No. 5" SENSOR ERROR (Er.35)

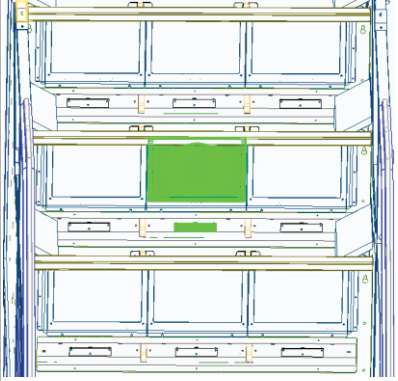
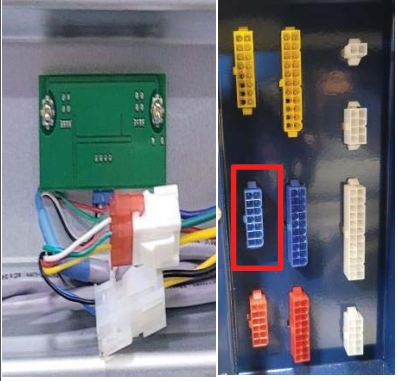
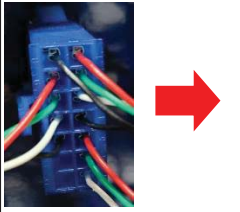
ERROR or LOCATION	P1	P2															
		 <table border="1" data-bbox="1203 165 1283 376"> <tr><td>8</td><td>1</td></tr> <tr><td>9</td><td>2</td></tr> <tr><td>10</td><td>3</td></tr> <tr><td>11</td><td>4</td></tr> <tr><td>12</td><td>5</td></tr> <tr><td>13</td><td>6</td></tr> <tr><td>14</td><td>7</td></tr> </table>	8	1	9	2	10	3	11	4	12	5	13	6	14	7	
8	1																
9	2																
10	3																
11	4																
12	5																
13	6																
14	7																
		<table border="1" data-bbox="928 385 1321 544"> <tr><td>5</td><td>Over 4.5V</td><td></td></tr> <tr><td>6</td><td>Below 1.0V</td><td></td></tr> <tr><td>7</td><td>Over 4.5V</td><td>undetected</td></tr> <tr><td></td><td>Below 0.2V</td><td>detect</td></tr> <tr><td>8</td><td>GND</td><td></td></tr> </table>	5	Over 4.5V		6	Below 1.0V		7	Over 4.5V	undetected		Below 0.2V	detect	8	GND	
5	Over 4.5V																
6	Below 1.0V																
7	Over 4.5V	undetected															
	Below 0.2V	detect															
8	GND																

► SOLUTION

1. TEST MODE → INPUT TEST

- CHECKER LED : "O" , "X" LED recognition status display
(Recognized: "O", Unrecognized: "X")
- SOUND output : "5" sound output when the sensor is recognized

2. CHECK :

- 1) Check sensor assembly (P1)
- 2) Check wiring connections (P1)
- 3) Check sensor voltage (P2)
- 4) Sensor PCB replacement
- 5) Main PCB replacement

PART NAME	CODE	PART NAME	CODE
BALL SENSOR PCB ASS'Y	ATTO0PCB001	MAIN PCB ASS'Y	ATTO0ASS001

12-12. CHECKER "No. 6" SENSOR ERROR (Er.36)

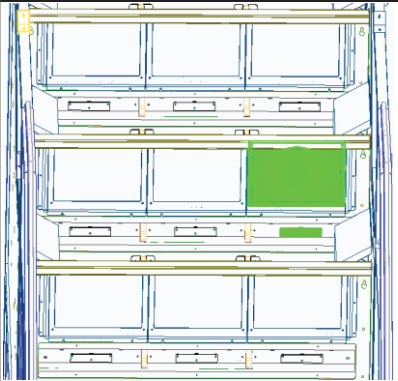
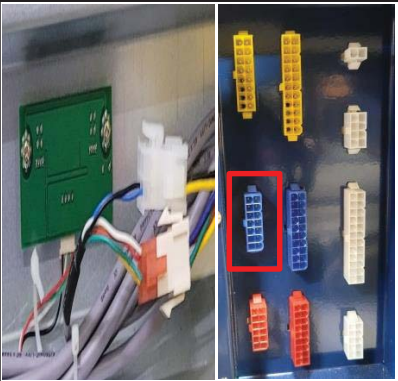
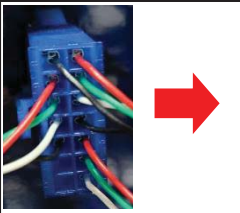
ERROR or LOCATION	P1	P2															
		 <table border="1" data-bbox="1203 1191 1283 1402"> <tr><td>8</td><td>1</td></tr> <tr><td>9</td><td>2</td></tr> <tr><td>10</td><td>3</td></tr> <tr><td>11</td><td>4</td></tr> <tr><td>12</td><td>5</td></tr> <tr><td>13</td><td>6</td></tr> <tr><td>14</td><td>7</td></tr> </table>	8	1	9	2	10	3	11	4	12	5	13	6	14	7	
8	1																
9	2																
10	3																
11	4																
12	5																
13	6																
14	7																
		<table border="1" data-bbox="928 1411 1321 1570"> <tr><td>9</td><td>Over 4.5V</td><td></td></tr> <tr><td>10</td><td>Below 1.0V</td><td></td></tr> <tr><td>11</td><td>Over 4.5V</td><td>undetected</td></tr> <tr><td></td><td>Below 0.2V</td><td>detect</td></tr> <tr><td>12</td><td>GND</td><td></td></tr> </table>	9	Over 4.5V		10	Below 1.0V		11	Over 4.5V	undetected		Below 0.2V	detect	12	GND	
9	Over 4.5V																
10	Below 1.0V																
11	Over 4.5V	undetected															
	Below 0.2V	detect															
12	GND																

► SOLUTION

1. TEST MODE → INPUT TEST

- CHECKER LED : "O" , "X" LED recognition status display
(Recognized: "O", Unrecognized: "X")
- SOUND output : "6" sound output when the sensor is recognized

2. CHECK :

- 1) Check sensor assembly (P1)
- 2) Check wiring connections (P1)
- 3) Check sensor voltage (P2)
- 4) Sensor PCB replacement
- 5) Main PCB replacement

PART NAME	CODE	PART NAME	CODE
BALL SENSOR PCB ASS'Y	ATTO0PCB001	MAIN PCB ASS'Y	ATTO0ASS001

12-13. CHECKER "No. 7" SENSOR ERROR (Er.37)

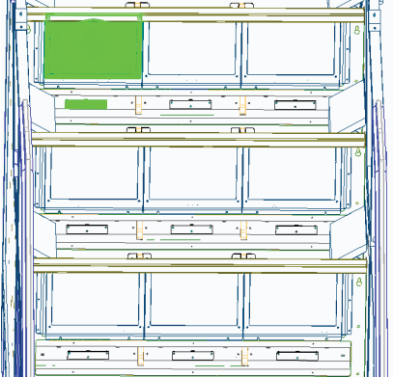
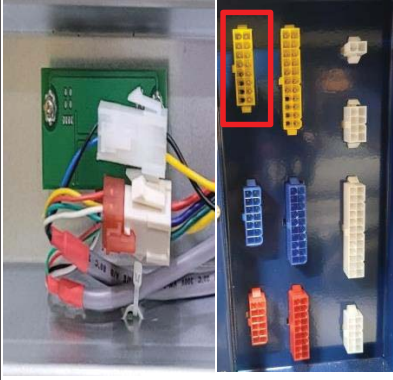
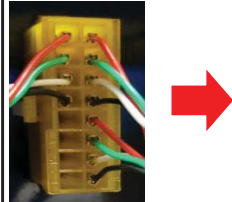
ERROR or LOCATION	P1	P2																														
		 <table border="1" data-bbox="1197 168 1284 369"> <tr><td>9</td><td>1</td></tr> <tr><td>10</td><td>2</td></tr> <tr><td>11</td><td>3</td></tr> <tr><td>12</td><td>4</td></tr> <tr><td>13</td><td>5</td></tr> <tr><td>14</td><td>6</td></tr> <tr><td>15</td><td>7</td></tr> <tr><td>16</td><td>8</td></tr> </table> <table border="1" data-bbox="933 380 1316 537"> <tr><td>1</td><td>Over 4.5V</td><td></td></tr> <tr><td>2</td><td>Below 1.0V</td><td></td></tr> <tr><td rowspan="2">3</td><td>Over 4.5V</td><td>undetected</td></tr> <tr><td>Below 0.2V</td><td>detect</td></tr> <tr><td>4</td><td>GND</td><td></td></tr> </table>	9	1	10	2	11	3	12	4	13	5	14	6	15	7	16	8	1	Over 4.5V		2	Below 1.0V		3	Over 4.5V	undetected	Below 0.2V	detect	4	GND	
9	1																															
10	2																															
11	3																															
12	4																															
13	5																															
14	6																															
15	7																															
16	8																															
1	Over 4.5V																															
2	Below 1.0V																															
3	Over 4.5V	undetected																														
	Below 0.2V	detect																														
4	GND																															

► SOLUTION

1. TEST MODE → INPUT TEST

- CHECKER LED : "O" , "X" LED recognition status display
(Recognized: "O", Unrecognized: "X")
- SOUND output : "7" sound output when the sensor is recognized

2. CHECK :

- 1) Check sensor assembly (P1)
- 2) Check wiring connections (P1)
- 3) Check sensor voltage (P2)
- 4) Sensor PCB replacement
- 5) Main PCB replacement

PART NAME	CODE	PART NAME	CODE
BALL SENSOR PCB ASS'Y	ATTO0PCB001	MAIN PCB ASS'Y	ATTO0ASS001

12-14. CHECKER "No. 8" SENSOR ERROR (Er.38)

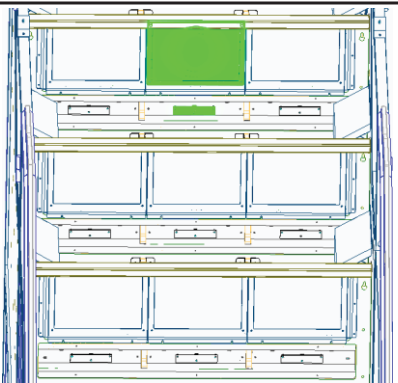
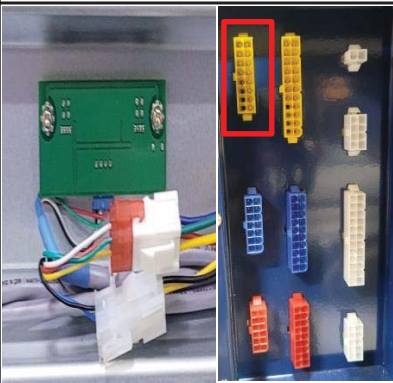
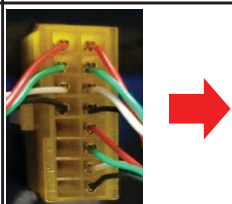
ERROR or LOCATION	P1	P2																														
		 <table border="1" data-bbox="1197 1198 1284 1400"> <tr><td>9</td><td>1</td></tr> <tr><td>10</td><td>2</td></tr> <tr><td>11</td><td>3</td></tr> <tr><td>12</td><td>4</td></tr> <tr><td>13</td><td>5</td></tr> <tr><td>14</td><td>6</td></tr> <tr><td>15</td><td>7</td></tr> <tr><td>16</td><td>8</td></tr> </table> <table border="1" data-bbox="933 1411 1316 1568"> <tr><td>5</td><td>Over 4.5V</td><td></td></tr> <tr><td>6</td><td>Below 1.0V</td><td></td></tr> <tr><td rowspan="2">7</td><td>Over 4.5V</td><td>undetected</td></tr> <tr><td>Below 0.2V</td><td>detect</td></tr> <tr><td>8</td><td>GND</td><td></td></tr> </table>	9	1	10	2	11	3	12	4	13	5	14	6	15	7	16	8	5	Over 4.5V		6	Below 1.0V		7	Over 4.5V	undetected	Below 0.2V	detect	8	GND	
9	1																															
10	2																															
11	3																															
12	4																															
13	5																															
14	6																															
15	7																															
16	8																															
5	Over 4.5V																															
6	Below 1.0V																															
7	Over 4.5V	undetected																														
	Below 0.2V	detect																														
8	GND																															

► SOLUTION

1. TEST MODE → INPUT TEST

- CHECKER LED : "O" , "X" LED recognition status display
(Recognized: "O", Unrecognized: "X")
- SOUND output : "8" sound output when the sensor is recognized

2. CHECK :

- 1) Check sensor assembly (P1)
- 2) Check wiring connections (P1)
- 3) Check sensor voltage (P2)
- 4) Sensor PCB replacement
- 5) Main PCB replacement

PART NAME	CODE	PART NAME	CODE
BALL SENSOR PCB ASS'Y	ATTO0PCB001	MAIN PCB ASS'Y	ATTO0ASS001

12-15. CHECKER "No. 9" SENSOR ERROR (Er.39)

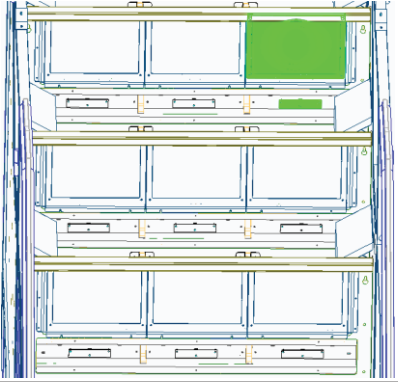
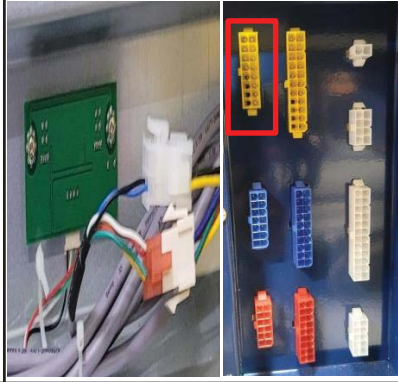
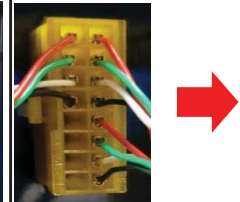
ERROR or LOCATION	P1	P2																
		 <table border="1" data-bbox="1197 168 1284 369"> <tr><td>9</td><td>1</td></tr> <tr><td>10</td><td>2</td></tr> <tr><td>11</td><td>3</td></tr> <tr><td>12</td><td>4</td></tr> <tr><td>13</td><td>5</td></tr> <tr><td>14</td><td>6</td></tr> <tr><td>15</td><td>7</td></tr> <tr><td>16</td><td>8</td></tr> </table>	9	1	10	2	11	3	12	4	13	5	14	6	15	7	16	8
9	1																	
10	2																	
11	3																	
12	4																	
13	5																	
14	6																	
15	7																	
16	8																	
		<table border="1" data-bbox="933 369 1316 548"> <tr><td>9</td><td>Over 4.5V</td><td></td></tr> <tr><td>10</td><td>Below 1.0V</td><td></td></tr> <tr><td>11</td><td>Over 4.5V</td><td>undetected</td></tr> <tr><td></td><td>Below 0.2V</td><td>detect</td></tr> <tr><td>12</td><td>GND</td><td></td></tr> </table>	9	Over 4.5V		10	Below 1.0V		11	Over 4.5V	undetected		Below 0.2V	detect	12	GND		
9	Over 4.5V																	
10	Below 1.0V																	
11	Over 4.5V	undetected																
	Below 0.2V	detect																
12	GND																	

► SOLUTION

1. TEST MODE → INPUT TEST

- CHECKER LED : "O" , "X" LED recognition status display
(Recognized: "O", Unrecognized: "X")
- SOUND output : "9" sound output when the sensor is recognized

2. CHECK :

- 1) Check sensor assembly (P1)
- 2) Check wiring connections (P1)
- 3) Check sensor voltage (P2)
- 4) Sensor PCB replacement
- 5) Main PCB replacement

PART NAME	CODE	PART NAME	CODE
BALL SENSOR PCB ASS'Y	ATTO0PCB001	MAIN PCB ASS'Y	ATTO0ASS001

12-16. TICKET ERROR (HEP)

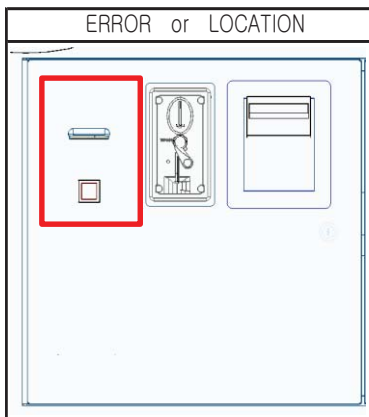

► SOLUTION

1. TEST MODE → TICKET TEST

2. CHECK :

- 1) Check whether the ticket paper is JAM
- 2) Check wiring connections
- 3) TICKET DISPENSER Replacement
- 4) Main PCB replacement

PART NAME	CODE	PART NAME	CODE
MAIN PCB ASS'Y	ATTO0ASS001		



ANDAMIRO WARRANTY POLICY



Andamiro warrants to the original purchaser that all of its products will be free from defects in material and workmanship.

Andamiro warrants the parts from date of shipment as follows.

- **One Year Limited Warranty : Electronic Boards**
- **6 Months Limited Warranty : Moving Parts**

For any key components within the warranty period, Andamiro will repair or replace defective components free of charge.

When placing a warranty request, the customer is requested to furnish the following information:

1. Name of the game.
2. Serial Number of the game.
3. A Detailed Description of the defect/s experienced.

This warranty does not apply to the defects caused due to misuse or abuse of the product.

Any alterations made to game or game parts will void this warranty.

For warranty details on our product range please visit our website, www.andamiro.com.

ANDAMIRO CO., LTD.
www.andamiro.com



TICTACTOE

BASKETBALL GAME

ANDAMIRO CO., LTD.

TEL : 82-31-909-2123~5

[ADDRESS OFFICE] 704-1 Techno Town, 138, Ilsan-ro, Ilsandong-gu, Goyang-si,
Gyeonggi-do, 10442 Rep of Korea

[FACTORY] 72 Nocheom-gil, Ilsandong-gu, Goyang-si, Gyeonggi-do, 10432 Rep of Korea

USA BRANCH

ANDAMIRO USA CORP.

TEL : 1-310-767-5800

[ADDRESS] 2222 Century Cir, Irving TX 75062 U.S.A

Homepage <http://www.andamiro.com/>